



EK 083S

EK SERIES HERMETIC LIQUID LINE FILTER DRIERS

The EK is a premium compacted bead liquid line filter designed for maximum filtration in both air conditioning and refrigeration applications.

FEATURES

- 99.9% filtration efficiency with minimal pressure drop
- Retains contaminants during system cycling and vibration
- Filtration first for more effective use of surface area of desiccant
- High moisture and acid removal capacity
- Specially formulated blend to protect POE oils
- Shock resistant steel shell construction
- Solid copper connections

SPECIFICATIONS

Desiccant Blend optimized for high water and acid capacity
 Filtration 20 microns
 Maximum Working Pressure..... 680 psig (47 bar)
 UL/CUL File Number SA3124
 Canadian CRN 0E21971.513467890YTN

MODEL NUMBER NOMENCLATURE - Example: EK 083SVV

SERIES	UNIT SIZE	CONNECTION SIZE	CONNECTION STYLE	ACCESS TYPE	SEQUENTIAL IDENTIFIER	CUSTOMER SPECIAL	PACK TYPE
EK	08	3	S	VV			
Hermetic Liquid Line Filter Driers	In Cubic In.	In 1/8" Increments	S = ODF FM = SAE Female X SAE Male SVCAP = ODF X Cap. Tube with Access Valve MF = SAE Male X SAE Female (Omit for SAE)	V = Single Access Valve VV = Dual Access Valve VCAP = Single Access Valve with Cap Tube Outlet Connection	Blank Thru -99	G = Customer Special (Omit for Standard)	B1 = Bulk Pack (Omit for Individual Pack)

EK SERIES LIQUID LINE FILTER DRIERS

UNIT SIZE (CUBIC INCHES)	INLET X OUTLET CONNECTION SIZE	ACCESS TYPE	MODEL NUMBER	ITEM NUMBER
3	1/4" X 1/4" SAE Flare	None	EK 032	060009
3	1/4" Female X 1/4" Male SAE Flare	None	EK 032FM	060011
3	1/4" Male X 1/4" Female SAE Flare	None	EK 032MF	060010
3	1/4" X 1/4" ODF	None	EK 032S	060012
3	1/4" ODF X Cap Tube	Single	EK 032SVCAP	063208
3	1/4" X 1/4" ODF	Dual	EK 032SVV	063908
3	3/8" X 3/8" SAE Flare	None	EK 033	060013
3	3/8" X 3/8" ODF	None	EK 033S	060014
5	1/4" X 1/4" SAE Flare	None	EK 052	047601
5	1/4" Male X 1/4" Female SAE Flare	None	EK 052MF	057013
5	1/4" X 1/4" ODF	None	EK 052S	047602
5	1/4" ODF X Cap Tube	Single	EK 052SVCAP	065846
5	1/4" X 1/4" ODF	Dual	EK 052SVV	065966
5	3/8" X 3/8" SAE Flare	None	EK 053	047603
5	3/8" X 3/8" ODF	None	EK 053S	047604
5	3/8" X 3/8" ODF	Dual	EK 053SVV	065963
8	1/4" X 1/4" SAE Flare	None	EK 082	047605
8	5/16" X 5/16" ODF	None	EK 0825S	049551
8	1/4" X 1/4" ODF	None	EK 082S	047606
8	3/8" X 3/8" SAE Flare	None	EK 083	047607
8	3/8" Male X 3/8" Female SAE Flare	None	EK 083MF	056906

EK SERIES LIQUID LINE FILTER DRIERS (CONTINUED)

UNIT SIZE (CUBIC INCHES)	INLET X OUTLET CONNECTION SIZE	ACCESS TYPE	MODEL NUMBER	ITEM NUMBER
8	3/8" X 3/8" ODF	None	EK 083S	047608
8	3/8" X 3/8" ODF	Dual	EK 083SVV	065964
8	1/2" X 1/2" SAE Flare	None	EK 084	047609
8	1/2" X 1/2" ODF	None	EK 084S	047610
16	1/4" X 1/4" SAE Flare	None	EK 162	047611
16	5/16" X 5/16 ODF	None	EK 1625S	056045
16	1/4" X 1/4" ODF	None	EK 162S	047612
16	3/8" X 3/8" SAE Flare	None	EK 163	047613
16	3/8" X 3/8" ODF	None	EK 163S	047614
16	3/8" X 3/8" ODF	Dual	EK 163SVV	065965
16	1/2" X 1/2" SAE Flare	None	EK 164	047615
16	1/2" X 1/2" ODF	None	EK 164S	047616
16	5/8" X 5/8" SAE Flare	None	EK 165	047617
16	5/8" X 5/8" ODF	None	EK 165S	047618
16	7/8" X 7/8" ODF	None	EK 167S	047619
30	3/8" X 3/8" SAE Flare	None	EK 303	048210
30	3/8" X 3/8" ODF	None	EK 303S	048211
30	1/2" X 1/2" SAE Flare	None	EK 304	048212
30	1/2" X 1/2" ODF	None	EK 304S	048213
30	5/8" X 5/8" SAE Flare	None	EK 305	048214
30	5/8" X 5/8" ODF	None	EK 305S	048215
30	3/4" X 3/4" SAE Flare	None	EK 306	048668
30	3/4" X 3/4" ODF	None	EK 306S	048216
30	7/8" X 7/8" ODF	None	EK 307S	048217
30	1-1/8" X 1-1/8" ODF	None	EK 309S	048218
41	3/8" X 3/8" SAE Flare	None	EK 413	048219
41	1/2" X 1/2" SAE Flare	None	EK 414	048220
41	1/2" X 1/2" ODF	None	EK 414S	048221
41	5/8" X 5/8" SAE Flare	None	EK 415	048222
41	5/8" X 5/8" ODF	None	EK 415S	048223
41	7/8" X 7/8" ODF	None	EK 417S	048224
41	1-1/8" X 1-1/8" ODF	None	EK 419S	048225
75	7/8" X 7/8" ODF	None	EK 757S	048228
75	1-1/8" X 1-1/8" ODF	None	EK 759S	048229

EK SERIES CAPACITY TABLE

MODEL NUMBER	ITEM NUMBER	FLOW CAPACITY TONS @ 1 PSI ΔP 1.4 (FOR KW, MULTIPLY TONS BY 3.5)						WATER CAPACITY 2 DROPS OF WATER 3																	
								R-22		R-134a		R-290 / R-600		R-404A / R-507		R-407C		R-410A		R-450A / R-513A		R452A / R452C / R-448A / R-449A		R-744	
		R-22 / R-410A / R-448A / R-449A	R-134a / R-450A / R-513A	R-290	R-404A / R-507 / R-452A / R-452C	R-407C	R-744	75°F	125°F	75°F	125°F	75°F	125°F	75°F	125°F	75°F	125°F	75°F	125°F	75°F	125°F	14°F	75°F		
EK 032FM	060011	2.2	2.0	2.4	1.4	2.1	2.8	40	33	40	37	46	42	38	37	33	25	21	19	41	46	41	45	30	34
EK 032	060009	2.2	2.0	2.4	1.4	2.1	2.8	40	33	40	37	46	42	38	37	33	25	21	19	41	46	41	45	30	34
EK 032MF	060010	2.2	2.0	2.4	1.4	2.1	2.8	40	33	40	37	46	42	38	37	33	25	21	19	41	46	41	45	30	34
EK 032S	060012	2.9	2.7	3.2	2.0	2.9	3.7	40	33	40	37	46	42	38	37	33	25	21	19	41	46	41	45	30	34
EK 033	060013	3.3	3.0	3.6	2.2	3.2	4.3	40	33	40	37	46	42	38	37	33	25	21	19	41	46	41	45	30	34
EK 033S	060014	3.3	3.0	3.6	2.2	3.2	4.3	40	33	40	37	46	42	38	37	33	25	21	19	41	46	41	45	30	34
EK 052	047601	2.3	2.1	2.5	1.5	2.2	3.0	114	97	116	106	125	114	109	106	95	75	64	58	112	123	111	122	81	89
EK 052MF	057013	2.3	2.1	2.5	1.5	2.2	3.0	114	97	116	106	125	114	109	106	95	75	64	58	112	123	111	122	81	89
EK 052S	047602	3.4	3.1	3.7	2.2	3.3	4.6	114	97	116	106	125	114	109	106	95	75	64	58	112	123	111	122	81	89

EK SERIES CAPACITY TABLE (CONTINUED)

MODEL NUMBER	ITEM NUMBER	FLOW CAPACITY TONS @ 1 PSI ΔP ^{1,4} (FOR KW, MULTIPLY TONS BY 3.5)						WATER CAPACITY ² DROPS OF WATER ³																	
								R-22		R-134a		R-290 / R-600		R-404A / R-507		R-407C		R-410A		R-450A / R-513A		R452A / R452C / R-448A / R-449A		R-744	
		R-22 / R-410A / R-448A / R-449A	R-134a / R-450A / R-513A	R-290	R-404A / R-507 / R-452A / R-452C	R-407C	R-744	75°F	125°F	75°F	125°F	75°F	125°F	75°F	125°F	75°F	125°F	75°F	125°F	75°F	125°F	75°F	125°F	14°F	75°F
EK 053	047603	3.8	3.5	4.2	2.5	3.7	4.9	114	97	116	106	125	114	109	106	95	75	64	58	112	123	111	122	81	89
EK 053S	047604	4.8	4.4	5.3	3.2	4.7	6.2	114	97	116	106	125	114	109	106	95	75	64	58	112	123	111	122	81	89
EK 082	047605	2.5	2.3	2.8	1.7	2.4	3.2	235	200	237	218	257	234	224	217	195	155	159	118	231	254	228	251	163	180
EK 0825S	049551	3.8	3.5	4.2	2.5	3.7	4.9	235	200	237	218	257	234	224	217	195	155	159	118	231	254	228	251	163	180
EK 082S	047606	3.6	3.3	4.0	2.4	3.5	4.4	235	200	237	218	257	234	224	217	195	155	159	118	231	254	228	251	163	180
EK 083	047607	4.3	4.0	4.7	2.9	4.3	5.5	235	200	237	218	257	234	224	217	195	155	159	118	231	254	228	251	163	180
EK 083MF	056906	4.3	4.0	4.7	2.9	4.3	5.5	235	200	237	218	257	234	224	217	195	155	159	118	231	254	228	251	163	180
EK 083S	047608	4.9	4.5	5.4	3.3	4.8	6.3	235	200	237	218	257	234	224	217	195	155	159	118	231	254	228	251	163	180
EK 084	047609	7.3	6.7	8.0	4.9	7.1	9.4	235	200	237	218	257	234	224	217	195	155	159	118	231	254	228	251	163	180
EK 084S	047610	7.7	7.1	8.5	5.1	7.5	9.9	235	200	237	218	257	234	224	217	195	155	159	118	231	254	228	251	163	180
EK 162	047611	2.5	2.3	2.8	1.7	2.4	3.2	368	313	371	341	403	366	350	340	305	240	206	186	361	398	357	392	260	286
EK 1625S	056045	3.4	3.1	3.7	2.2	3.3	4.4	368	313	371	341	403	366	350	340	305	240	206	186	361	398	357	392	260	286
EK 162S	047612	3.4	3.1	3.7	2.2	3.3	4.4	368	313	371	341	403	366	350	340	305	240	206	186	361	398	357	392	260	286
EK 163	047613	4.2	3.9	4.6	2.8	4.1	5.4	368	313	371	341	403	366	350	340	305	240	206	186	361	398	357	392	260	286
EK 163S	047614	4.8	4.4	5.3	3.2	4.7	6.2	368	313	371	341	403	366	350	340	305	240	206	186	361	398	357	392	260	286
EK 164	047615	7.8	6.1	8.6	4.2	6.5	10.1	368	313	371	341	403	366	350	340	305	240	206	186	361	398	357	392	260	286
EK 164S	047616	9.2	8.5	10.1	6.2	9.0	11.9	368	313	371	341	403	366	350	340	305	240	206	186	361	398	357	392	260	286
EK 165	047617	10.5	9.7	11.6	7.0	10.3	13.5	368	313	371	341	403	366	350	340	305	240	206	186	361	398	357	392	260	286
EK 165S	047618	10.9	10.1	12.0	7.3	10.7	14.1	368	313	371	341	403	366	350	340	305	240	206	186	361	398	357	392	260	286
EK 167S	047619	16.8	15.5	18.5	11.2	16.5	21.7	368	313	371	341	403	366	350	340	305	240	206	186	361	398	357	392	260	286
EK 303	048210	4.7	4.3	5.2	3.1	4.6	6.1	657	561	664	611	—	—	627	608	548	434	515	355	648	713	640	703	458	504
EK 303S	048211	6.8	6.3	7.5	4.6	6.7	8.8	657	561	664	611	—	—	627	608	548	434	515	355	648	713	640	703	458	504
EK 304	048212	8.8	8.1	9.7	5.9	8.6	11.4	657	561	664	611	—	—	627	608	548	434	515	355	648	713	640	703	458	504
EK 304S	048213	10.8	10.0	11.9	7.2	10.6	13.9	657	561	664	611	—	—	627	608	548	434	515	355	648	713	640	703	458	504
EK 305	048214	11.5	10.6	12.7	7.7	11.3	14.8	657	561	664	611	—	—	627	608	548	434	515	355	648	713	640	703	458	504
EK 306S	048216	16.0	14.8	17.6	10.7	15.7	20.6	657	561	664	611	—	—	627	608	548	434	515	355	648	713	640	703	458	504
EK 307S	048217	18.2	16.8	20.0	12.2	17.9	23.5	657	561	664	611	—	—	627	608	548	434	515	355	648	713	640	703	458	504
EK 309S	048218	21.2	19.6	23.3	14.2	20.8	27.3	657	561	664	611	—	—	627	608	548	434	515	355	648	713	640	703	458	504
EK 413	048219	4.7	4.3	5.2	3.1	4.6	6.1	919	785	938	854	—	—	876	850	765	607	715	465	906	997	895	984	638	702
EK 414	048220	11.3	10.4	12.4	7.5	11.1	14.6	919	785	938	854	—	—	876	850	765	607	715	465	906	997	895	984	638	702
EK 414S	048221	11.7	10.8	12.9	7.8	11.5	15.1	919	785	938	854	—	—	876	850	765	607	715	465	906	997	895	984	638	702
EK 415	048222	13.0	12.0	14.3	8.7	12.8	16.8	919	785	938	854	—	—	876	850	765	607	715	465	906	997	895	984	638	702
EK 417S	048224	22.0	20.3	24.2	14.7	21.6	28.4	919	785	938	854	—	—	876	850	765	607	715	465	906	997	895	984	638	702
EK 419S	048225	30.0	27.7	33.0	20.1	29.4	38.7	919	785	938	854	—	—	876	850	765	607	715	465	906	997	895	984	638	702
EK 757S	048228	24.1	22.2	26.5	16.1	23.6	31.1	2159	1880	2159	2019	—	—	2019	2019	1810	1460	1460	1111	2170	2387	2142	2356	1578	1737
EK 759S	048229	35.4	32.7	38.9	23.7	34.8	45.7	2159	1880	2159	2019	—	—	2019	2019	1810	1460	1460	1111	2170	2387	2142	2356	1578	1737

¹ All ratings in accordance with ARI Standard 710-04. 86oF liquid refrigerant temperature

5°F saturated vapor temperature

3.1 lbs./min./ton for R-134a

2.9 lbs./min./ton for R-22 and R-407C

4.0 lbs./min./ton for R-404A/507 and R-12

2.7 lbs./min./ton for R-410A

⁵ Since there is currently no ARI standard for R-744, values are based on 1 ton of refrigeration at 20°F liquid refrigerant temperature and -20°F saturated vapor temperature.

² Water Capacities are based on:

Equilibrium Point Dryness (EPD) of:

50 parts per million for R-134a,

R404-A/507, R-410A, R-407C, and R-744

60 parts per million for R-22

15 parts per million for R-12

³ 20 drops of water = 1 gram = 1 cc

⁴ For 2 PSI ΔP, Multiply values by 1.4

LIQUID REFRIGERANT HOLDING CAPACITY-OUNCES

UNIT SIZE	R-12		R-134a		R-22		R-407C		R-410A		R-404A/R-507		R-502		R-744	
	75°F	125°F	75°F	125°F	75°F	125°F	75°F	125°F	75°F	125°F	75°F	125°F	75°F	125°F	20°F	-20°F
03	2.9	2.6	2.6	2.3	2.6	2.3	2.5	2.1	2.3	1.9	2.3	1.9	2.7	2.3	2.1	2.3
05	6.5	5.9	6.0	5.4	5.9	5.3	5.6	4.9	5.3	4.4	5.2	4.4	6.0	5.3	4.8	5.3
08	8.3	7.6	7.6	6.9	7.5	6.8	7.2	6.3	6.7	5.7	6.6	5.6	7.7	6.8	6.1	6.7
16	10.2	9.4	9.4	8.6	9.3	8.4	8.9	7.8	8.3	7.0	8.2	6.9	9.5	8.4	7.5	8.3
30	28.7	26.3	26.4	23.9	26.1	23.5	24.9	21.9	23.3	19.6	22.9	19.4	26.7	23.4	21.1	23.4
41	40.0	36.4	36.9	33.1	36.4	32.5	34.7	30.3	32.5	27.2	31.9	26.8	37.2	32.4	29.2	32.4
75	72.4	66.3	66.7	60.3	65.8	59.2	62.8	55.2	58.7	49.5	57.7	48.9	67.2	59.0	53.1	58.9



ADK 163S

ADK SERIES HERMETIC LIQUID LINE FILTER DRIERS

The ADK is a solid core liquid line filter drier good for use in residential air conditioning and refrigeration systems.

FEATURES

- Solid copper connections
- High moisture and acid removal capacity
- Corrosion resistant epoxy powder paint finish

SPECIFICATIONS

Desiccant blend..... Optimized for high water and acid capacity
 Filtration 40 microns
 Maximum working pressure 680 psig (47 bar)
 UL/CUL file numberSA 3124
 Canadian CRN0E21971.513467890YTN

MODEL NUMBER NOMENCLATURE - EXAMPLE: ADK 032SVCAP

SERIES	UNIT SIZE	CONNECTION SIZE	CONNECTION TYPE	ACCESS	SEQUENTIAL IDENTIFIER	CUSTOMER SPECIAL	PACK TYPE
ADK	03	2	S	VCAP			
Hermetic Core Style Liquid Line Filter Driers	In Cubic In.	In 1/8" Increments	S = Solder (ODF) (Omit for Flare (SAE))	V = Single Access Valve VCAP = Single Access Valve with Cap Tube Outlet (Omit for no access valve)	Blank Thru -99	G = Customer Special (Omit for Standard)	B1 = Bulk Pack (Omit for Individual Pack)

ADK SERIES REFRIGERANT FILTER DRIERS

UNIT SIZE (CUBIC INCHES)	INLET X OUTLET CONNECTION SIZE & TYPE	ACCESS TYPE	MODEL NUMBER	ITEM NUMBER
03	1/4" X 1/4" SAE	None	ADK 032	059874
03	1/4" X 1/4" ODF	None	ADK 032S	052451
03	1/4" ODF X Cap Tube	Single	ADK 032SVCAP	063909
03	3/8" X 3/8" SAE	None	ADK 033	023157
03	3/8" X 1/4" ODF	None	ADK 033/2S	063496
03	3/8" X 3/8" ODF	None	ADK 033S	053172
05	1/4" X 1/4" SAE	None	ADK 052	060125
05	1/4" X 1/4" ODF	None	ADK 052S	060126
05	3/8" X 3/8" SAE	None	ADK 053	060127
05	3/8" X 3/8" ODF	None	ADK 053S	060128
08	1/4" X 1/4" SAE	None	ADK 082	060129
08	1/4" X 1/4" ODF	None	ADK 082S	060130
08	3/8" X 3/8" SAE	None	ADK 083	060131
08	3/8" X 3/8" ODF	None	ADK 083S	060132
08	1/2" X 1/2" SAE	None	ADK 084	060133
08	1/2" X 1/2" ODF	None	ADK 084S	060134
16	1/4" X 1/4" SAE	None	ADK 162	059820
16	1/4" X 1/4" ODF	None	ADK 162S	059838
16	3/8" X 3/8" SAE	None	ADK 163	059839
16	3/8" X 3/8" ODF	None	ADK 163S	060795
16	1/2" X 1/2" SAE	None	ADK 164	059840
16	1/2" X 1/2" ODF	None	ADK 164S	059841
16	5/8" X 5/8" SAE	None	ADK 165	059842
16	5/8" X 5/8" ODF	None	ADK 165S	059843

ADK SERIES REFRIGERANT FILTER DRIERS (CONT'D)

UNIT SIZE (CUBIC INCHES)	INLET X OUTLET CONNECTION SIZE & TYPE	ACCESS TYPE	MODEL NUMBER	ITEM NUMBER
30	3/8" X 3/8" SAE	None	ADK 303	060172
30	3/8" X 3/8" ODF	None	ADK 303S	058507
30	1/2" X 1/2" SAE	None	ADK 304	060173
30	1/2" X 1/2" ODF	None	ADK 304S	060176
30	5/8" X 5/8" SAE	None	ADK 305	060174
30	5/8" X 5/8" ODF	None	ADK 305S	060177
30	7/8" X 7/8" ODF	None	ADK 307S	060178
30	1-1/8" X 1-1/8" ODF	None	ADK 309S	060179
41	3/8" X 3/8" SAE	None	ADK 413	060182
41	1/2" X 1/2" SAE	None	ADK 414	060183
41	1/2" X 1/2" ODF	None	ADK 414S	060185
41	5/8" X 5/8" SAE	None	ADK 415	060184
41	5/8" X 5/8" ODF	None	ADK 415S	060186
41	7/8" X 7/8" ODF	None	ADK 417S	060187
41	1-1/8" X 1-1/8" ODF	None	ADK 419S	060188
75	7/8" X 7/8" ODF	None	ADK 757S	060190
75	1-1/8" X 1-1/8" ODF	None	ADK 759S	060191

ADK SERIES CAPACITY TABLE

MODEL NUMBER	CONN.	FLOW CAPACITY TONS @ 1 PSI ΔP ^{1,4} (FOR KW, MULTIPLY TONS BY 3.5)							WATER CAPACITY ² (DROPS OF WATER ³)																	
		R-22/ R-448A/ R-449A	R-134a/ R-450A/ R-513A	R-290	R-410A	R-407C	R-404A / R-507	R-744	R-22		R-134a		R-290		R-407C		R-410A		R-404A / 507		R-448A / R-449A		R-450A / R-513A		R-744	
									75°F	125°F	75°F	125°F	75°F	125°F	75°F	125°F	75°F	125°F	75°F	125°F	75°F	125°F	75°F	125°F	14°F	75°F
ADK 032	1/4 SAE	2.1	1.9	2.3	2.1	2.0	1.4	2.7	69	63	74	68	62	59	57	46	47	36	76	72	49	45	63	57	58	64
ADK 032S	1/4 ODF	2.5	2.3	2.8	2.5	2.4	1.7	3.2																		
ADK 033	3/8 SAE	2.9	2.7	3.2	2.9	2.9	2.0	3.7																		
ADK 033S	3/8 ODF	3.3	3.0	3.6	3.3	3.2	2.2	4.3	180	130	195	180	161	152	150	120	125	95	200	190	128	116	162	147	144	169
ADK 052	1/4 SAE	2.2	2.0	2.4	2.2	2.1	1.4	2.8																		
ADK 052S	1/4 ODF	3.1	2.9	3.4	3.1	3.1	2.1	4.0																		
ADK 053	3/8 SAE	4.0	3.7	4.4	4.0	3.9	2.7	5.2	250	225	265	245	227	214	205	165	170	130	275	260	180	164	228	207	198	233
ADK 53S	3/8 ODF	4.9	4.5	5.4	4.9	4.8	3.3	6.3																		
ADK 082	1/4 SAE	2.2	2.0	2.4	2.2	2.1	1.4	2.8																		
ADK 082S	1/4 ODF	3.4	3.1	3.7	3.4	3.3	2.2	4.4	265	330	390	360	322	304	300	240	250	190	400	380	256	233	323	294	328	386
ADK 083	3/8 SAE	4.7	4.3	5.2	4.7	4.6	3.1	6.1																		
ADK 083S	3/8 ODF	4.6	4.2	5.1	4.6	4.5	3.0	5.9																		
ADK 084	1/2 SAE	7.3	6.7	8.0	7.3	7.1	4.9	9.4	810	740	865	800	—	—	675	540	555	420	895	845	614	558	775	705	676	796
ADK 084S	1/2 ODF	7.6	7.0	8.4	7.6	7.4	5.1	9.8																		
ADK 162	1/4 SAE	2.2	2.0	2.4	2.2	2.1	1.4	2.8																		
ADK 163	3/8 SAE	4.8	4.4	5.3	4.8	4.7	3.2	6.2	265	330	390	360	322	304	300	240	250	190	400	380	256	233	323	294	328	386
ADK 163S	3/8 ODF	5.3	4.9	5.8	5.3	5.2	3.6	6.8																		
ADK 164	1/2 SAE	9.0	8.3	9.9	9.0	8.8	6.0	11.6																		
ADK 164S	1/2 ODF	9.3	8.6	10.2	9.3	9.1	6.2	12.0	810	740	865	800	—	—	675	540	555	420	895	845	614	558	775	705	676	796
ADK 165	5/8 SAE	12.8	11.8	14.1	12.8	12.5	8.6	16.5																		
ADK 165S	5/8 ODF	14.2	13.1	15.6	14.2	13.9	9.5	18.3																		
ADK 167S	7/8 ODF	17.3	16.0	19.0	17.3	17.0	11.8	22.3	810	740	865	800	—	—	675	540	555	420	895	845	614	558	775	705	676	796
ADK 303	3/8 SAE	5.1	4.7	—	5.1	5.0	3.4	6.6																		
ADK 304	1/2 SAE	9.3	8.6	—	9.3	9.1	6.2	12.0																		
ADK 304S	1/2 ODF	9.5	8.8	—	9.5	9.4	6.4	12.3	810	740	865	800	—	—	675	540	555	420	895	845	614	558	775	705	676	796
ADK 305	5/8 SAE	15.0	13.8	—	15.0	14.7	10.0	19.4																		

ADK SERIES CAPACITY TABLE (CONTINUED)

MODEL NUMBER	CONN.	FLOW CAPACITY TONS @ 1 PSI ΔP ^{1,4} (FOR kW, MULTIPLY TONS BY 3.5)							WATER CAPACITY ² (DROPS OF WATER ³)																	
		R-22/ R-448A/ R-449A	R-134a/ R-450A/ R-513A	R-290	R-410A	R-407C	R-404A / R-507	R-744	R-22		R-134a		R-290		R-407C		R-410A		R-404A / 507		R-448A / R-449A		R-450A / R-513A		R-744	
									75°F	125°F	75°F	125°F	75°F	125°F	75°F	125°F	75°F	125°F	75°F	125°F	75°F	125°F	75°F	125°F	75°F	125°F
ADK 305S	5/8 ODF	15.7	14.5	—	15.7	15.4	10.5	20.3	810	740	865	800	—	—	675	540	555	420	895	845	614	558	775	705	676	796
ADK 306S	3/4 ODF	17.1	15.8	—	17.1	16.8	11.5	22.1																		
ADK 307S	7/8 ODF	18.9	17.4	—	18.9	18.5	12.6	24.4																		
ADK 309S	1-1/8 ODF	27.0	24.9	—	27.0	26.5	18.0	34.8																		
ADK 413	3/8 SAE	5.1	4.7	—	5.1	5.0	3.4	6.6	1140	1010	1210	1100	—	—	945	740	780	580	1260	1156	818	744	1033	1033	900	1060
ADK 414	1/2 SAE	10.6	9.8	—	10.6	10.4	7.1	13.7																		
ADK 414S	1/2 ODF	11.6	10.7	—	11.6	11.4	7.8	15.0																		
ADK 415	5/8 SAE	16.9	15.6	—	16.9	16.6	11.3	21.8																		
ADK 415S	5/8 ODF	17.9	16.5	—	17.9	17.5	12.0	23.1																		
ADK 417S	7/8 ODF	22.0	20.3	—	22.0	21.7	14.7	28.4																		
ADK 419S	1-1/8 ODF	27.3	25.2	—	27.3	26.8	18.3	35.2																		
ADK 757S	7/8 ODF	37.1	34.2	—	37.1	36.3	24.8	47.9																		
ADK 759S	1-1/8 ODF	40.4	37.3	—	40.4	39.6	27.0	52.1																		

¹ All ratings in accordance with ARI Standard 710-04. 86oF liquid refrigerant temperature
 5°F saturated vapor temperature
 3.1 lbs./min./ton for R-134a
 2.9 lbs./min./ton for R-22 and R-407C
 4.0 lbs./min./ton for R-404A/507 and R-12
 2.7 lbs./min./ton for R-410A
⁵ Since there is currently no ARI standard for R-744, values are based on 1 ton of refrigeration at 20°F liquid refrigerant temperature and -20°F saturated vapor temperature.

² Water Capacities are based on:
 Equilibrium Point Dryness (EPD) of:
 50 parts per million for R-134a,
 R404-A/507, R-410A, R-407C, and R-744
 60 parts per million for R-22
 15 parts per million for R-12

³ 20 drops of water = 1 gram = 1 cc
⁴ For 2 PSI ΔP, Multiply values by 1.4

LIQUID REFRIGERANT HOLDING CAPACITY-OUNCES

UNIT SIZE	R-12		R-22 / R-448A / R-449A		R290		R-134a / R-450A / R-513A		R-407C		R-410A		R-404A / 507		R-502		R-744	
	75°F	125°F	75°F	125°F	75°F	125°F	75°F	125°F	75°F	125°F	75°F	125°F	75°F	125°F	75°F	125°F	20°F	-20°F
03	2.4	2.2	2.2	2.0	0.9	0.8	2.2	2.0	2.1	1.9	2.0	1.7	1.9	1.7	2.7	2.3	1.8	2.0
05	5.9	6.0	5.4	5.4	2.2	2	5.5	5.5	5.2	5.0	4.8	4.5	4.7	4.5	6.0	5.3	4.9	5.4
08	8.0	7.4	7.3	6.6	3	2.7	7.4	6.7	7.0	6.2	6.5	5.5	6.4	5.5	7.7	6.8	5.9	6.5
16	14.5	12.5	13.2	11.2	5.4	4.9	13.4	11.4	12.6	10.4	11.7	9.4	11.6	9.3	9.5	8.4	10.1	11.2
30	21.8	19.9	19.8	17.8	8.1	7.3	20.1	18.1	18.9	16.6	17.4	14.9	17.4	14.7	26.7	23.4	16.0	17.7
41	29.3	26.8	26.6	23.9	11	9.9	26.9	24.4	25.4	22.3	23.7	20.0	23.3	19.7	37.2	32.4	21.4	23.8
75	52.8	48.3	48.0	43.1	19.8	17.9	48.6	43.9	45.8	40.2	42.8	36.0	42.1	35.6	67.2	59.0	38.7	42.9



BFK 083S

BFK SERIES HERMETIC LIQUID LINE BI-DIRECTIONAL FILTER DRIERS

The BFK is a liquid line filter drier for heat pump applications.

FEATURES

- Available 5 to 30 Cubic In. size
- Internal check valve allows flow and filtration in either direction eliminating the need for external check valves
- High moisture and acid removal capacity
- Corrosion resistant epoxy powder paint finish
- Approved for POE oils

SPECIFICATIONS

Desiccant Blend..... Optimized for high water and acid capacity
 Filtration 40 microns
 Maximum Working Pressure..... 680 psig (47 bar)
 UL/CUL File Number SA3124
 Canadian CRN 0E21971.513467890YTN

MODEL NUMBER NOMENCLATURE - EXAMPLE: BFK 165S

SERIES	UNIT SIZE	CONNECTION SIZE	CONNECTION STYLE	SEQUENTIAL IDENTIFIER	CUSTOMER SPECIAL	PACK TYPE
BFK	16	5	S			
Hermetic Liquid Line Bi-Directional Filter Driers	In Cubic In.	In 1/8" Increments	S = ODF	Blank Thru -99	G = Customer Special (Omit for Standard)	B1 = Bulk Pack (Omit for Individual Pack)

BFK BI-DIRECTIONAL LIQUID LINE FILTER DRIERS

UNIT SIZE (CUBIC INCHES)	INLET X OUTLET CONNECTION SIZE	MODEL NUMBER	ITEM NUMBER
5	1/4" X 1/4" SAE	BFK 052	062300
5	1/4" X 1/4" ODF	BFK 052S	062425
5	3/8" X 3/8" SAE	BFK 053	062254
5	3/8" X 3/8" ODF	BFK 053S	062255
8	3/8" X 3/8" SAE	BFK 083	043321
8	3/8" X 3/8" ODF	BFK 083S	043323
8	1/2" X 1/2" SAE	BFK 084	043325
8	1/2" X 1/2" ODF	BFK 084S	043327
8	5/8" X 5/8" SAE	BFK 085	043728
8	5/8" X 5/8" ODF	BFK 085S	043730
16	3/8" X 3/8" SAE	BFK 163	043330
16	3/8" X 3/8" ODF	BFK 163S	043333
16	1/2" X 1/2" SAE	BFK 164	043335
16	1/2" X 1/2" ODF	BFK 164S	043337
16	5/8" X 5/8" SAE	BFK 165	043732
16	5/8" X 5/8" ODF	BFK 165S	043734
16	7/8" X 7/8" ODF	BFK 167S	058589
30	3/8" X 3/8" ODF	BFK 303S	063077
30	1/2" X 1/2" SAE	BFK 304	063078
30	1/2" X 1/2" ODF	BFK 304S	063079
30	5/8" X 5/8" SAE	BFK 305	063080
30	5/8" X 5/8" ODF	BFK 305S	063081
30	3/4" X 3/4" ODF	BFK 306S	063083
30	7/8" X 7/8" ODF	BFK 307S	063084
30	1-1/8" X 1-1/8" ODF	BFK 309S	063451

BFK SERIES CAPACITY TABLE

MODEL NUMBER	CONNECTION	FLOW CAPACITY TONS @ 1 PSI ΔP ^{1,4} (FOR KW, MULTIPLY TONS BY 3.5)				WATER CAPACITY ² DROPS OF WATER ³							
		R-22	R-410A	R-407C	R-744	R-22		R-407C		R-410A		R-744	
						75°F	125°F	75°F	125°F	75°F	125°F	14°F	75°F
BFK-05 2	1/4 SAE	1.6	1.6	1.6	2.1	73	66	58	42	39	35	81	89
BFK-05 2S	1/4 ODF	2.2	2.2	2.2	2.8								
BFK-05 3	3/8 SAE	3.5	3.5	3.4	4.5								
BFK-05 3S	3/8 ODF	4.0	4.0	3.9	5.2								
BFK-08 3	3/8 SAE	4.5	4.5	4.4	5.8	159	144	106	79	85	75	136	150
BFK-08 3S	3/8 ODF	5.1	5.1	5.0	6.6								
BFK-08 4	1/2 SAE	6.4	6.4	6.3	8.3								
BFK-08 4S	1/2 ODF	6.7	6.7	6.6	8.6								
BFK-08 5	5/8 SAE	7.2	7.2	7.0	9.3								
BFK-08 5S	5/8 ODF	8.1	8.1	7.9	10.4	323	294	237	179	178	160	221	260
BFK-16 3	3/8 SAE	4.6	4.6	4.5	5.9								
BFK-16 3S	3/8 ODF	5.2	5.2	5.1	6.7								
BFK-16 4	1/2 SAE	7.7	7.7	7.6	9.9								
BFK-16 4S	1/2 ODF	8.1	8.1	7.9	10.4								
BFK-16 5	5/8 SAE	8.3	8.3	8.1	10.7								
BFK-16 5S	5/8 ODF	8.7	8.7	8.5	11.2	585	532	452	345	415	293	453	533
BFK-30 3S	3/8 ODF	5.8	5.8	5.7	7.5								
BFK-30 4	1/2 SAE	7.6	7.6	7.5	9.8								
BFK-30 4S	1/2 ODF	9.7	9.7	9.5	12.5								
BFK-30 5	5/8 SAE	10.3	10.3	10.1	13.3								
BFK-30 5S	5/8 ODF	14.2	14.2	13.9	18.3								
BFK-30 6S	3/4 ODF	16.0	16.0	15.7	20.6								
BFK-30 7S	7/8 ODF	16.7	16.7	16.4	21.5								
BFK-30 9S	1 1/8 ODF	18.0	18.0	17.5	23.2								

¹ All ratings in accordance with ARI Standard 710-04. 86oF liquid refrigerant temperature
 5°F saturated vapor temperature
 3.1 lbs./min./ton for R-134a
 2.9 lbs./min./ton for R-22 and R-407C
 4.0 lbs./min./ton for R-404A/507 and R-12
 2.7 lbs./min./ton for R-410A
⁵ Since there is currently no ARI standard for R-744, values are based on 1 ton of refrigeration at 20°F liquid refrigerant temperature and -20°F saturated vapor temperature.

² Water Capacities are based on:
 Equilibrium Point Dryness (EPD) of:
 50 parts per million for R-134a,
 R404-A/507, R-410A, R-407C, and R-744
 60 parts per million for R-22
 15 parts per million for R-12

³ 20 drops of water = 1 gram = 1 cc
⁴ For 2 PSI ΔP, Multiply values by 1.4

LIQUID REFRIGERANT HOLDING CAPACITY-OUNCES

UNIT SIZE	R-22		R-407C		R-410A		R-744	
	75°F	125°F	75°F	125°F	75°F	125°F	20°F	-20°F
05	4.6	4.2	4.4	3.9	4.1	3.5	3.7	4.1
08	7.7	6.9	7.3	6.4	6.9	5.8	6.2	6.9
16	14.2	12.7	13.5	11.8	12.6	10.6	1.4	12.7
30	21.0	18.7	20.0	17.4	19.6	16.5	16.8	18.7



BSL 0835S



BSB 083S



BSS 167S

BUILDER SERIES HERMETIC FILTER DRIERS

The Builder Series is a hermetic filter drier that provides economical system protection for air conditioning and heat pump applications.

FEATURES

- ODF solid copper connections for easy install
- Desiccant blend optimized for high water and acid capacity
- Corrosion resistant epoxy powder paint finish
- BSB and BSS feature solid core construction
- BSL features compacted bead construction with 20 micron filtration for maximum moisture and acid removal while protecting POE oil
- BSL filters at both the inlet and outlet and retains contaminants during system cycling and vibration

SPECIFICATIONS

Desiccant blend..... Optimized for high water capacity and acid capacity
 Maximum working pressure 680 psig (47 bar)
 UL/CUL file numberSA 7175
 Filtration40 microns (BSB and BSS only)
 20 microns (BSL only)
 Canadian CRN0E21971.513467890YTN

MODEL NUMBER NOMENCLATURE - EXAMPLE: BSB 083S

SERIES	TYPE	UNIT SIZE	CONNECTION SIZE	CONNECTION STYLE	SEQUENTIAL IDENTIFIER	CUSTOMER SPECIAL	PACK TYPE
BS	B	08	3	S			
Hermetic Filter Driers	B = Bi-Directional L = Liquid S = Suction	In Cubic In.	In 1/8" Increments	S = ODF (Omit for SAE)	Blank Thru -99	G = Customer Special (Omit for Standard)	B1 = Bulk Pack (Omit for Individual Pack)

BUILDER SERIES HERMETIC FILTER DRIERS

LINE TYPE	UNIT SIZE (CUBIC INCHES)	INLET X OUTLET CONNECTION SIZE	WATER CAPACITY DROPS R-410A @ 125°F	FLOW CAPACITY TONS R-410A	MODEL NUMBER	ITEM NUMBER
Liquid	5	3/8" X 3/8" ODF	56	5.3	BSL 053S	066758
Liquid	8	3/8" X 3/8" ODF	108	5.3	BSL 083S	066759
Liquid	8	1/2" X 1/2" ODF	108	7.6	BSL 084S	066760
Liquid	16	3/8" X 3/8" ODF	151	5.3	BSL 163S	066761
Liquid	16	1/2" X 1/2" ODF	151	7.6	BSL 164S	066763
Bi-Directional	8	3/8" X 3/8" ODF	70	5.1	BSB 083S	066130
Bi-Directional	16	3/8" X 3/8" ODF	125	5.1	BSB 163S	066131
Suction	16	5/8" X 5/8" ODF	51	3.5	BSS 165S	066126
Suction	16	3/4" X 3/4" ODF	51	4.2	BSS 166S	066127
Suction	16	7/8" X 7/8" ODF	51	4.2	BSS 167S	066128
Suction	30	5/8" X 5/8" ODF	84	3.5	BSS 305S	066100
Suction	30	3/4" X 3/4" ODF	84	5.5	BSS 306S	066101
Suction	30	7/8" X 7/8" ODF	84	6.0	BSS 307S	066129
Suction	30	1-1/8" X 1-1/8" ODF	84	6.2	BSS 309S	066102



BOK 304SHH

BOK SERIES HERMETIC LIQUID LINE FILTER DRIERS

The BOK is a liquid line filter drier for burnout clean-up and wax removal.

FEATURES

- Activated carbon blend for soluble contaminant and wax removal
- Solid copper connections
- Corrosion resistant epoxy powder paint finish

SPECIFICATIONS

Filtration 40 microns
 Maximum Working Pressure..... 680 psig (47 bar)
 UL/CUL File Number SA3124
 Canadian CRN0E21971.513467890YTN

MODEL NUMBER NOMENCLATURE - Example: BOK 305S-HH

SERIES	UNIT SIZE	CONNECTION SIZE	CONNECTION STYLE	DESICCANT TYPE	SEQUENTIAL IDENTIFIER	CUSTOMER SPECIAL	PACK TYPE
BOK	30	5	S	HH			
Hermetic Liquid Line Filter Driers	In Cubic In.	In 1/8" Increments	S = ODF	HH = Activated Carbon	Blank Thru -99	G = Customer Special (Omit for Standard)	B1 = Bulk Pack (Omit for Individual Pack)

BOK LIQUID LINE FILTER DRIERS & CAPACITY TABLE

MODEL NUMBER	ITEM NUMBER	UNIT SIZE (CUBIC INCHES)	INLET X OUTLET CONN. SIZE	FLOW CAPACITY ¹⁴ TONS @ 1 PSI ΔP (FOR KW, MULTIPLY TONS BY 3.5)						WATER CAPACITY ² DROPS OF WATER ³															
				R-22 / R-448A / R-449A	R-134a / R-450A / R-513A	R-404A / R-507	R-407C	R-410A	R-744	R-22		R-134a		R-404A / R-507		R-407C		R-410A		R-448A / R-449A		R-450A / R-513A		R-744	
										75°F	125°F	75°F	125°F	75°F	125°F	75°F	125°F	75°F	125°F	75°F	125°F	75°F	125°F	14°F	75°F
BOK 082HH	060223	8	1/4" X 1/4" SAE	1.6	1.5	1.1	1.6	1.6	2.1	78	59	88	71	93	71	74	45	66	38	32	30	40	37	51	63
BOK 082SHH	064591	8	1/4" X 1/4" ODF	3.4	3.1	2.2	3.3	3.4	4.4																
BOK 083HH	060224	8	3/8" X 3/8" SAE	4.2	3.9	2.8	4.1	4.2	5.4																
BOK 083SHH	064572	8	3/8" X 3/8" ODF	4.6	4.2	3.0	4.5	4.6	5.9																
BOK 162HH	060240	16	1/4" X 1/4" SAE	1.6	1.5	1.1	1.6	1.6	2.1	153	117	171	141	182	141	91	56	77	41	67	61	83	76	93	113
BOK 163HH	060241	16	3/8" X 3/8" SAE	4.7	4.3	3.1	4.6	4.7	6.1																
BOK 163SHH	060242	16	3/8" X 3/8" ODF	6.3	5.8	4.2	6.2	6.3	8.1																
BOK 164HH	060228	16	1/2" X 1/2" SAE	9.3	8.6	6.2	9.1	9.3	12.0																
BOK 164SHH	060229	16	1/2" X 1/2" ODF	11.1	10.2	7.4	10.9	11.1	14.3																
BOK 165HH	060230	16	5/8" X 5/8" SAE	13.9	12.8	9.3	13.6	13.9	17.9																
BOK 165SHH	060231	16	5/8" X 5/8" ODF	13.9	12.8	9.3	13.6	13.9	17.9																
BOK 303HH	060232	30	3/8" X 3/8" SAE	4.7	4.3	3.1	4.6	4.7	6.1																
BOK 304HH	060233	30	1/2" X 1/2" SAE	10.7	9.9	7.2	10.5	10.7	13.8	267	204	300	245	318	247	234	146	160	94	119	108	148	135	167	203
BOK 304SHH	060234	30	1/2" X 1/2" ODF	11.7	10.8	7.8	11.5	11.7	15.1																
BOK 305HH	060235	30	5/8" X 5/8" SAE	14.6	13.5	9.8	14.3	14.6	18.8																
BOK 305SHH	060236	30	5/8" X 5/8" ODF	15.8	14.6	10.6	15.5	15.8	20.4																

BOK LIQUID LINE FILTER DRIERS & CAPACITY TABLE (CONTINUED)

MODEL NUMBER	ITEM NUMBER	UNIT SIZE (CUBIC INCHES)	INLET X OUTLET CONN. SIZE	FLOW CAPACITY ¹⁴ TONS @ 1 PSI ΔP (FOR KW, MULTIPLY TONS BY 3.5)						WATER CAPACITY ² DROPS OF WATER ³															
				R-22 / R-448A / R-449A	R-134a / R-450A / R-513A	R-404A / R-507	R-407C	R-410A	R-744	R-22		R-134a		R-404A / R-507		R-407C		R-410A		R-448A / R-449A		R-450A / R-513A		R-744	
										75°F	125°F	75°F	125°F	75°F	125°F	75°F	125°F	75°F	125°F	75°F	125°F	75°F	125°F	75°F	125°F
BOK 414HH	060237	41	1/2" X 1/2" SAE	11.1	10.2	7.4	10.9	11.1	14.3	379	282	427	344	454	342	256	155	220	125	163	150	204	186	249	305
BOK 415HH	060238	41	5/8" X 5/8" SAE	17.7	16.3	11.8	17.4	17.7	22.8																
BOK 415SHH	064593	41	5/8" X 5/8" ODF	17.7	16.3	14.4	21.1	17.7	22.8																
BOK 417SHH	060239	41	7/8" X 7/8" ODF	21.5	19.8	14.4	21.1	21.5	27.7																

¹ All ratings in accordance with ARI Standard 710-04. 86oF liquid refrigerant temperature
 5°F saturated vapor temperature
 3.1 lbs./min./ton for R-134a
 2.9 lbs./min./ton for R-22 and R-407C
 4.0 lbs./min./ton for R-404A/507 and R-12
 2.7 lbs./min./ton for R-410A
 5 Since there is currently no ARI standard for R-744, values are based on 1 ton of refrigeration at 20°F liquid refrigerant temperature and -20°F saturated vapor temperature.

² Water Capacities are based on:
 Equilibrium Point Dryness (EPD) of:
 50 parts per million for R-134a, R404-A/507, R-410A, R-407C, and R-744
 60 parts per million for R-22
 15 parts per million for R-12

³ 20 drops of water = 1 gram = 1 cc
⁴ For 2 PSI ΔP, Multiply values by 1.4

LIQUID REFRIGERANT HOLDING CAPACITY-OUNCES

UNIT SIZE	R-134a		R-22		R-407C		R-410A		R-404A / 507		R-448A / R-449A		R-450A / R-513A		R-744	
	75°F	125°F	75°F	125°F	75°F	125°F	75°F	125°F	75°F	125°F	75°F	125°F	75°F	125°F	20°F	-20°F
08	6.7	6.0	6.6	5.9	6.3	5.5	5.9	4.9	5.8	4.9	6.0	5.4	6.4	5.8	5.3	5.9
16	12.8	11.5	12.6	11.3	12.0	10.5	11.2	9.4	11.1	9.3	11.7	10.4	12.4	11.2	10.1	11.3
30	20.1	18.1	19.8	17.8	18.9	16.6	17.6	14.9	17.4	14.7	18.3	16.3	19.4	17.6	16.0	17.7
41	26.9	24.4	26.6	23.9	25.4	22.3	23.7	20.0	23.3	19.7	24.5	21.8	26.1	23.6	21.4	23.8

CU SERIES SPUN COPPER HERMETIC LIQUID LINE FILTER DRIERS

The CU series is a high capacity spun copper solid core filter drier ideal for superior corrosion resistance in ocean going vessels and residential coastal applications. Models available for replacement in residential air conditioning or refrigeration equipment.

FEATURES

- All copper construction for extreme corrosion resistance
- 100% molecular sieve solid core drier

SPECIFICATIONS

Maximum Working Pressure..... 600 psig (41 bar)
 Filtration Standard 40 microns
 Fractional Tonnage 100 microns
 UL/CUL File Number SA7175
 Canadian CRN 0E21971.513467890YTN

MODEL NUMBER NOMENCLATURE - Example: CU 1635

SERIES	UNIT SIZE	CONNECTION SIZE	CONNECTION TYPE	SEQUENTIAL IDENTIFIER	CUSTOMER SPECIAL	PACK TYPE
CU	16	3	S			
Hermetic Liquid Line Filter Driers	In Cubic In.	In 1/8" Increments	S = ODF (Omit S for special)	Blank Thru -99	G = Customer Special (Omit for Standard)	B1 = Bulk Pack (Omit for Individual Pack)

CU SERIES SPUN COPPER HERMETIC LIQUID LINE FILTER DRIERS

PARKER EQUIVALENT	UNIT SIZE (CUBIC INCHES)	INLET CONNECTION	OUTLET CONNECTION	FILTRATION (MICRONS)	MAXIMUM WORKING PRESSURE (PSIG)	FLOW CAPACITY TONS @ 1 PSI ΔP ¹⁴ (FOR KW, MULTIPLY TONS BY 3.5)		WATER CAPACITY ² (DROPS OF WATER ³)												MODEL NUMBER	ITEM NUMBER							
						R-22 / R-410A		R-22	R-134a	R-290	R-404A / R-507	R-407C	R-410A	R-448A / R-449A	R-450A / R-513A													
						R-134a / R-450A / R-513A	R-290	R-404A / R-507 / R-452A	R-407A / R-407C / R-448A / R-449A	75°F	125°F	75°F	125°F	75°F	125°F	75°F	125°F	75°F	125°F			75°F	125°F					
CU LLD 3-3S	3	3/8 ODF	3/8 ODF	40	600	2.8	2.6	3.1	1.9	2.7	87	81	93	87	109	103	96	93	72	57	60	54	87	79	110	100	CU 033S	064389
CU LLD 5-3S	5	3/8 ODF	3/8 ODF	40	600	2.8	2.6	3.1	1.9	2.7	101	93	108	101	126	119	112	108	82	63	70	62	99	90	137	125	CU 053S	064391
CU LLD 8-3S	8	3/8 ODF	3/8 ODF	40	600	3.8	3.5	4.2	2.5	3.7	191	177	205	191	236	223	212	205	156	122	131	117	188	171	237	216	CU 083S	064393
CU LLD 16-3S	16	3/8 ODF	3/8 ODF	40	600	4.3	4.0	4.7	2.9	4.2	257	237	277	257	340	320	287	277	207	158	177	157	270	245	341	310	CU 163S	064395

CU SERIES SPUN COPPER HERMETIC LIQUID LINE FRACTIONAL TONNAGE FILTER DRIERS

MMS-80	—	1/4 ODF	1/4 ODF	100	500	0.5	0.3	0.6	0.3	0.5	25	22	26	23	33	31	26	23	23	21	17	15	38	35	38	35	CU 80	064023
619	—	1/4 ODF	CAP	100	500	0.5	0.3	0.6	0.3	0.5	25	22	26	23	33	31	26	23	23	21	17	15	38	35	38	35	CU 619	064026
620	—	5/16 ODF	CAP	100	500	2.0	1.0	2.2	0.8	1.9	50	44	53	46	66	63	53	46	43	39	33	29	76	69	76	69	CU 620	064027
621	—	5/16 ODF	CAP	100	500	2.0	1.0	2.2	0.8	1.9	50	44	53	46	66	63	53	46	43	39	33	29	76	69	76	69	CU 621	064119
MMS-200	—	5/16 ODF 3/8 ODF	5/16 ODF, 3/8 ODF	100	500	1.0	0.8	1.1	0.6	0.9	50	44	53	46	66	63	53	46	43	39	33	29	76	69	76	69	CU 200	064024
319F	—	5/16 ODF	CAP	100	500	2.0	1.0	2.2	0.8	1.9	75	66	80	76	99	94	79	75	65	59	50	44	114	104	114	104	CU 319	064025

¹ All ratings in accordance with ARI Standard 710-04. 86oF liquid refrigerant temperature 5°F saturated vapor temperature
 3.1 lbs./min./ton for R-134a
 2.9 lbs./min./ton for R-22 and R-407C
 4.0 lbs./min./ton for R-404A/507 and R-12
 2.7 lbs./min./ton for R-410A

² Water Capacities are based on: Equilibrium Point Dryness (EPD) of: 50 parts per million for R-134a, R404-A/507, R-410A, R-407C, and R-744 60 parts per million for R-22

³ 20 drops of water = 1 gram = 1 cc
⁴ For 2 PSI ΔP, Multiply values by 1.4



ALF 032MF

ALF SERIES HERMETIC LIQUID LINE FILTERS

The ALF is a liquid line refrigerant filter for recovery, recycle and reclaim usage.
The ALF is also used for protecting solenoid and expansion valve parts from debris.

FEATURES

- Filtering media maximizes removal of finer particles
- Corrosion resistant epoxy powder paint finish

SPECIFICATIONS

Filtration 40 microns
 Maximum Working Pressure..... 680 psig (47 bar)
 UL/CUL File NumberSA 3124
 Canadian CRN0E21971.513467890YTN

MODEL NUMBER NOMENCLATURE - EXAMPLE: ALF 032S

SERIES	UNIT SIZE	CONNECTION SIZE	CONNECTION STYLE	SEQUENTIAL IDENTIFIER	CUSTOMER SPECIAL	PACK TYPE
ALF	03	2	S			
Hermetic Liquid Line Filters	In Cubic In.	In 1/8" Increments	S = ODF MF = ODM x ODF (Omit for SAE)	Blank Thru -99	G = Customer Special (Omit for Standard)	B1 = Bulk Pack (Omit for Individual Pack)

ALF LIQUID LINE FILTERS

UNIT SIZE (CUBIC INCHES)	INLET X OUTLET CONNECTION SIZE	MODEL NUMBER	ITEM NUMBER
3	1/4" SAE Male X 1/4" SAE Flare Female	ALF 032MF	057193
3	1/4" X 1/4" ODF	ALF 032S	056618
3	3/8" X 3/8" ODF	ALF 033S	057140
3	1/2" X 1/2" ODF	ALF 034S	056645

CAPACITY TABLE

RECOVERY, RECYCLE AND RECLAIM REFRIGERANT FLOW CAPACITY (LBS./MIN. LIQUID)		
R-134a / R-450A / R-513A	R-22 / R-410A / R-448A / R-449A	R-404A / R-507
7.6	8.0	8.0



STAS 9617T

STAS SERIES TAKE-APART LIQUID AND SUCTION FILTER DRIERS

The STAS is a replaceable core filter drier for use in large commercial air conditioning and refrigeration systems. The STAS-CO is specifically designed for CO₂ (R-744) systems.

FEATURES

- Slotted cover/unique internal hardware for hassle-free installation
- Full flow fittings for low pressure drop
- Corrosion resistant epoxy powder paint finish
- Sturdy steel shells for long life
- Solid copper connections
- 100 mesh outlet screen

SPECIFICATIONS

Filtration40 microns with core
 Maximum Working Pressure..... SV version = 500 psig (35 bar)
T version = 680 psig (47 bar)
 UL/CUL File Number SA7175
 Canadian CRN0E21971.513467890YTN

MODEL NUMBER NOMENCLATURE - EXAMPLE: STAS CO489T

SERIES	DESIGN	UNIT SIZE	CONNECTION SIZE	SYSTEM SERVICE	SEQUENTIAL IDENTIFIER	CUSTOMER SPECIAL	PACK TYPE
STAS	CO	48	9	T	VV		
Steel Take-Apart Liquid or Suction Filter Driers	CO = For use with R-744 (Omit for Standard Refrigerants)	In Cubic In.	In 1/8" Increments	T = Liquid Line Service SV = Suction Line Service	Blank Thru -99	G = Customer Special (Omit for Standard)	B1 = Bulk Pack (Omit for Individual Pack)

STAS SERIES LIQUID AND SUCTION LINE FILTER DRIERS

(STAS uses 48 cubic in. Cores and shipped without filter or filter drier cores. See filter drier cores and filters section)

UNIT SIZE (CUBIC INCHES)	INLET X OUTLET CONNECTION SIZE	ACCESS TYPE	NUMBER OF 48 IN. CORES	MODEL NUMBER	ITEM NUMBER
48	5/8" X 5/8" ODF	Tap Access	1	STAS 485T	053001
48	5/8" X 5/8" ODF	Tap Access	1	STAS CO485T	066725
48	7/8" X 7/8" ODF	Tap Access	1	STAS 487T	053003
48	7/8" X 7/8" ODF	Tap Access	1	STAS CO487T	066726
48	1-1/8" X 1-1/8" ODF	Tap Access	1	STAS 489T	053005
48	1-1/8" X 1-1/8" ODF	Tap Access	1	STAS CO489T	066727
48	1-3/8" X 1-3/8" ODF	Single	1	STAS 4811SV	053938
48	1-3/8" X 1-3/8" ODF	Tap Access	1	STAS 4811T	053007
48	1-5/8" X 1-5/8" ODF	Single	1	STAS 4813SV	053043
48	1-5/8" X 1-5/8" ODF	Tap Access	1	STAS 4813T	053375
48	2-1/8" X 2-1/8" ODF	Single	1	STAS 4817SV	053044
48	2-5/8" X 2-5/8" ODF	Single	1	STAS 4821SV	053045
96	7/8" X 7/8" ODF	Tap Access	2	STAS 967T	053010
96	1-1/8" X 1-1/8" ODF	Tap Access	2	STAS 969T	053012
96	1-3/8" X 1-3/8" ODF	Tap Access	2	STAS CO9611T	066729
96	1-3/8" X 1-3/8" ODF	Tap Access	2	STAS 9611T	053014
96	1-1/8" X 1-1/8" ODF	Tap Access	2	STAS CO969T	066728

STAS SERIES LIQUID AND SUCTION LINE FILTER DRIERS (CONTINUED)

UNIT SIZE (CUBIC INCHES)	INLET X OUTLET CONNECTION SIZE	ACCESS TYPE	NUMBER OF 48 IN. CORES	MODEL NUMBER	ITEM NUMBER
96	1-5/8" X 1-5/8" ODF	Tap Access	2	STAS 9613T	053017
96	2-1/8" X 2-1/8" ODF	Single	2	STAS 9617SV	053047
96	2-1/8" X 2-1/8" ODF	Tap Access	2	STAS 9617T	053018
96	2-5/8" X 2-5/8" ODF	Single	2	STAS 9621SV	053048
96	3-1/8" X 3-1/8" ODF	Single	2	STAS 9625SV	059739
144	1-1/8" X 1-1/8" ODF	Tap Access	3	STAS 1449T	053020
144	1-3/8" X 1-3/8" ODF	Tap Access	3	STAS 1441T	053022
144	1-5/8" X 1-5/8" ODF	Tap Access	3	STAS 14413T	053024
144	2-1/8" X 2-1/8" ODF	Tap Access	3	STAS 14417T	053025
192	1-3/8" X 1-3/8" ODF	Tap Access	4	STAS 19211T	053028
192	1-5/8" X 1-5/8" ODF	Tap Access	4	STAS 19213T	053030
192	2-1/8" X 2-1/8" ODF	Tap Access	4	STAS 19217T	053031

SV style includes stainless steel bolts and access valve
T style can be used for suction by removing pipe plug and installing x-11562-2

STAS SERIES PARTS LIST

DESCRIPTION	MODEL NUMBER	ITEM NUMBER
STAS Steel Liquid and Suction Line Filter Drier Cover Bolts (Stainless Steel - Suction Line service)	X-25787-7	053121
STAS Felt Set	27394-1	060278
STAS Steel Liquid and Suction Line Filter Drier Gasket Set	X-11983-1	027453
STAS Handle	26446-1	053812
STAS Steel Liquid and Suction Line Filter Drier Mounting Bracket	X-28747-1	061715
STAS Spring	26439-1	060258
BTAS and STAS Suction Line Filter Drier Access Valve with Cap (V-Option)	X-11562-2	037409
STAS Inlet Retainer	26447-1	053813
STAS Steel Liquid and Suction Line Filter Drier Retainer Assembly for 48 cu. In.	X-27458-1	060274
STAS Steel Liquid and Suction Line Filter Drier Retainer Assembly for 96 cu. In.	X-27458-2	060275
STAS Steel Liquid and Suction Line Filter Drier Retainer Assembly for 144 cu. In.	X-27458-3	060276
STAS Steel Liquid and Suction Line Filter Drier Retainer Assembly for 192 cu. In.	X-27458-4	060277
STAS Flange cover assembly includes flange cover, compression spring, pipe plug and grade 5 bolts	X-12176-3	054046
Replacement Filter (Suction Only) for ADKS and Similar Competitive Filters Not for BTAS	F 100	095762
Replacement Filter (Suction Only) Reverse Flow for STAS and Similar Competitive Filters Not for BTAS	F 48R	047664
Filter Drier Core for High Acid and Water Removal in ADKS and STAS Shells and Similar Competitive Take-Apart Filter Drier Shells Not for BTAS	H 100	089338
Block Filter Drier Core for High Acid and Water Removal in STAS Shells and Similar Competitive Take-Apart Filter Drier Shells Not for BTAS	H 48	059542
Filter Drier Core for Highest Water Removal in STAS Shells and Similar Competitive Take-Apart Filter Drier Shells Not for BTAS	HX 48	062549
Universal Replacement Cores, Filter Cores Use In STAS Shells and Similar Competitive Take-Apart Filter Drier Shells. May Not Be Used for BTAS.	RW 48	061238
Premium Universal Replacement Filter Drier Core for ADKS Shells and Similar Competitive Take-Apart Filter Drier Shells Not for BTAS	UK 100	062424
Premium Universal Replacement Filter Drier Core for STAS Shells and Similar Competitive Take-Apart Filter Drier Shells Not for BTAS	UK 48	061617
Burnout Clean Up Filter Drier Core for ADKS Shells and Similar Competitive Take-Apart Filter Drier Shells Not for BTAS	W 100HH	043582
Burnout Clean Up Filter Drier Core for STAS Shells and Similar Competitive Take-Apart Filter Drier Shells Not for BTAS	W 48HH	061235



Capacity
Tables

STAS SERIES CAPACITY TABLE

CONNECTIONS	LIQUID FLOW CAPACITY TONS @ 1 PSI ΔP ¹					MODEL NUMBER	ITEM NUMBER
	R-22 / R-410A / R-448A / R-449A	R-134a / R-450A / R-513A	R-404A / 507	R-407C	R-744		
5/8 ODF	22	21	15	21	28	STAS 485T	053001
7/8 ODF	41	38	27	39	53	STAS 487T	053003
1-1/8 ODF	58	53	38	56	75	STAS 489T	053005
1-3/8 ODF	81	75	53	78	—	STAS 4811T	053007
1-5/8 ODF	89	81	58	85	—	STAS 4813T	053375
7/8 ODF	45	42	30	43	—	STAS 967T	053010
1-1/8 ODF	71	65	47	68	92	STAS 969T	053012
1-3/8 ODF	87	80	57	83	112	STAS 9611T	053014
1-5/8 ODF	100	92	65	95	—	STAS 9613T	053017
1-1/8 ODF	72	66	47	69	—	STAS 1449T	053020
1-3/8 ODF	100	92	65	96	—	STAS 14411T	053022
1-5/8 ODF	101	93	66	97	—	STAS 14413T	053024
2-1/8 ODF	120	110	78	115	—	STAS 14417T	053025
1-1/8 ODF	102	94	67	98	—	STAS 19211T	053028
1-5/8 ODF	113	103	74	108	—	STAS 19213T	053030
2-1/8 ODF	123	113	80	117	—	STAS 19217T	053031

All ratings in accordance with ARI standard 710-04. 86oF liquid refrigerant temperature.

5F saturated vapor temperature

3.1 lbs./min./ton for R-134a

2.9 lbs./min./ton for R-22 and R-407C

4.0lbs./min./ton for R-404A/507 and R-12

For 2 PSI (triangle)P, Multiply values by 1.4

For kW, multiply by 3.5*

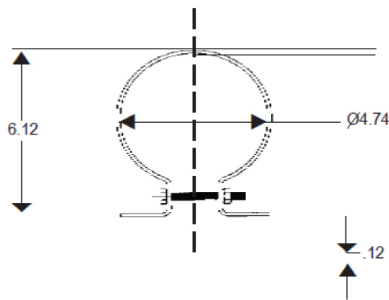

Mounting Bracket for STAS 48*

* More than one mounting bracket may be required for shell sizes 96 and above.

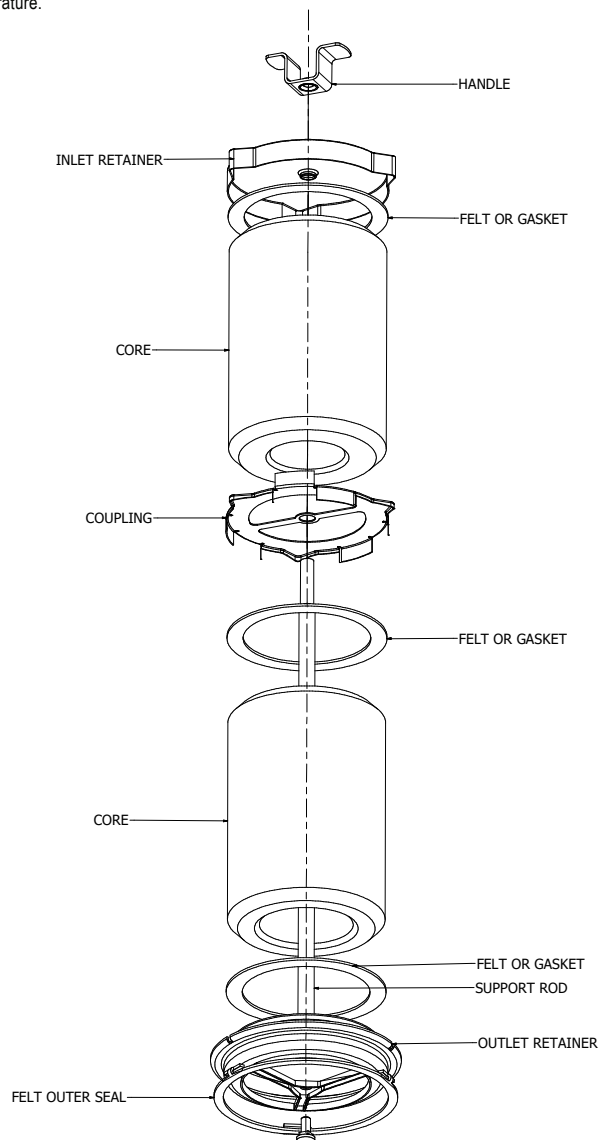



ADKS 30017T

ADKS SERIES TAKE-APART LIQUID & SUCTION LINE FILTER DRIERS

The ADKS is a replaceable core filter drier for use in the liquid or suction line for very large commercial air conditioning and refrigerant systems.

FEATURES

- Full flow fittings for low pressure drop
- Corrosion resistant epoxy powder paint finish
- Sturdy steel shells for long life durability

SPECIFICATIONS

Filtration (With Core)..... 40 microns
 Maximum Working Pressure..... 500 psig* (35 bar)
 UL/CUL File NumberSA 3124
 Bolt Torque.....35 ft-lbs

* Not suitable for R-410A applications above 500 psig.

MODEL NUMBER NOMENCLATURE - EXAMPLE: ADKS 30013T

SERIES	UNIT SIZE	CONNECTION SIZE	ACCESS	SEQUENTIAL IDENTIFIER	CUSTOMER SPECIAL	PACK TYPE
ADKS	300	13	T			
Take-Apart Liquid and Suction Line Filters Driers	In Cubic In.	In 1/8" Increments	T = Tap Access Connection (Omit for no access valve)	Blank Thru -99	G = Customer Special (Omit for Standard)	B1 = Bulk Pack (Omit for Individual Pack)

ADKS LIQUID AND SUCTION LINE FILTER DRIER

UNIT SIZE (CUBIC INCHES)	INLET X OUTLET CONNECTION SIZE	ACCESS TYPE	NUMBER OF 100 IN ³ CORES	FLOW CAPACITY IN TONS @ 1 PSI ΔP 1, 2				MODEL NUMBER	ITEM NUMBER
				R-22 / R-410A / R-448A / R-449A	R-134a / R-450A / R-513A	R-404 / 507	R-407C		
300	1-5/8" X 1-5/8" ODF	Tap Access	3	110	102	73	108	ADKS 30013T	026570
300	2-1/8" X 2-1/8" ODF	Tap Access	3	160	148	107	157	ADKS 30017T	037978
400	2-1/8" X 2-1/8" ODF	Tap Access	4	170	157	114	167	ADKS 40017T	032105
400	2-5/8" X 2-5/8" ODF	Tap Access	4	180	166	120	177	ADKS 40021T	037570

Models are shipped without filter cores or filter drier cores. Use 100 cubic inch cores.

ADKS SERIES REPLACEMENT PARTS

DESCRIPTION	MODEL NUMBER	ITEM NUMBER
ADKS-300, ADKS-400 Flange Cover	X-12176-2	027467
ADKS 300 cu. In. Shell Strainer Replacement Kit	X-10574-5	039967
ADKS 400 cu. In. Shell Strainer Replacement Kit	X-10574-6	038315
Gasket Set (Includes Cover Gasket)	X-11983-2	027454
ADKS Series Replacement Flange and Plug Assembly	X-12176-3	054046
ADKS Series Gasket Set	X-11983-2	027454

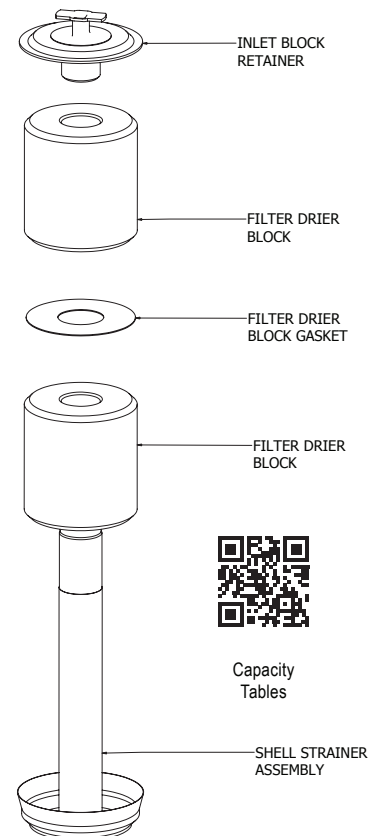



H 48

FILTER DRIER CORES AND FILTERS FOR TAKE-APART SHELLS

Universal replacement cores and filter cores for use in our ADKS and STAS shells and similar competitive Take-Apart type filter drier shells. May not be used for BTAS.

FEATURES

- Water capacities to suit specific system conditions
- Exceptional acid capacities for normal system protection, or to effectively clean-up following a compressor burnout
- Activated carbon blend for soluble contaminant and wax removal (W-HH Series)

MODEL NUMBER NOMENCLATURE - EXAMPLE: H 48

SERIES	UNIT SIZE
H	48
Universal Replacement Cores and Filters	In Cubic In.

FILTER DRIER CORES AND FILTERS

FUNCTION	DESCRIPTION ³	WATER CAPACITY ¹ (DROPS OF WATER ²)																MODEL NUMBER ³	ITEM NUMBER
		R-22		R-134a		R-404A / R-507		R-407C		R-410A		R-448A / R-449A		R-450A / R-513A		R-744			
		75°F	125°F	75°F	125°F	75°F	125°F	75°F	125°F	75°F	125°F	75°F	125°F	75°F	125°F	14°F	75°F		
High Acid and Water Removal Premium Universal Replacement	Premium Universal Replacement Filter Drier Core for ADKS Shells and Similar Competitive Take-Apart Filter Drier Shells	2574	2345	2769	2550	2868	2710	2182	1682	1616	1303	1683	1531	2787	2437	1887	2073	UK 100	062424
High Acid and Water Removal Premium Universal Replacement	Premium Universal Replacement Filter Drier Core for STAS Shells and Similar Competitive Take-Apart Filter Drier Shells	1181	1072	1272	1168	1319	1241	1033	786	976	707	942	857	1332	1150	1184	1388	UK 48	061617
High Acid and Water Removal	Filter Drier Core for High Acid and Water Removal in ADKS Shells and Similar Competitive Take-Apart Filter Drier Shells	962	673	1112	834	1199	839	726	418	672	364	238	219	1109	758	526	550	H 100	089338
High Acid and Water Removal	Block Filter Drier Core for High Acid and Water Removal in STAS Shells and Similar Competitive Take-Apart Filter Drier Shells	597	436	676	538	721	535	445	285	380	226	388	225	643	475	274	321	H 48	059542
High Acid Removal	Block Filter Drier Core for High Acid Removal in STAS not for BTAS	363	254	415	340	457	343	225	95	210	86	106	98	388	225	186	218	D 48	059541
Highest Water Removal	Filter Drier Core for Highest Water Removal in STAS Shells and Similar Competitive Take-Apart Filter Drier Shells	1600	1491	1710	1600	1765	1710	1459	1161	1280	930	1050	974	1932	1744	929	1027	HX 48	062549
Refrigerant Reclaim / Maximum Moisture Removal	Filter Drier Core / Filter for CFC, HCFC Refrigerant Reclamation and Maximum Moisture Removal	1037	790	1096	920	1090	940	750	530	650	420	421	384	643	475	576	621	RH 48	061237
Refrigerant Reclaim / Burnout with Wax Removal	Universal Replacement Cores for STAS Shells and Similar Competitive Take-Apart Filter Drier Shells	532	380	583	493	600	482	380	230	350	197	147	135	444	306	294	308	RW 48	061238

FILTER DRIER CORES AND FILTERS (CONTINUED)

FUNCTION	DESCRIPTION ³	WATER CAPACITY ¹ (DROPS OF WATER ²)																MODEL NUMBER ³	ITEM NUMBER
		R-22		R-134a		R-404A / R-507		R-407C		R-410A		R-448A / R-449A		R-450A / R-513A		R-744			
		75°F	125°F	75°F	125°F	75°F	125°F	75°F	125°F	75°F	125°F	75°F	125°F	75°F	125°F	14°F	75°F		
Burnout Cleanup with Charcoal	Burnout Clean Up Filter Drier Core for ADKS Shells and Similar Competitive Take-Apart Filter Drier Shells	938	621	1077	812	1162	792	629	363	573	307	248	228	960	663	510	534	W 100HH	043582
Burnout Cleanup with Charcoal	Burnout Clean Up Filter Drier Core for STAS Shells and Similar Competitive Take-Apart Filter Drier Shells	335	226	387	294	417	289	290	165	249	130	119	109	444	306	328	386	W 48HH	061235
Solid Contaminant Filter (Suction Only)	Replacement Filter (Suction Only) for STAS Not for BTAS	—	—	—	—	—	—	—	—	—	—	—	—	—	—	—	—	F 48	089559
Solid Contaminant Filter (Suction Only) Reverse Flow	Replacement Filter (Suction Only) Reverse Flow for STAS and Similar Competitive Filters Not for BTAS	—	—	—	—	—	—	—	—	—	—	—	—	—	—	—	—	F 48R	047664
Solid Contaminant Filter (Suction Only)	Replacement Filter (Suction Only) for ADKS and Similar Competitive Filters Not for BTAS	—	—	—	—	—	—	—	—	—	—	—	—	—	—	—	—	F 100	095762

¹ Water Capacities are based on:
50 parts per million for R-134a, R404-A/R-410A and R-407C
60 parts per million for R-22
15 parts per million for R-12

² 20 drops of water = 1 gram = 1 cc Equilibrium Point Dryness (EPD) of:

³ D-42 and H-42 include one neoprene composite lid gasket and one core gasket. All other cores include a universal neoprene composite gasket kit which includes 2 sizes of replacement lid gaskets, and gaskets for the top and bottom of the core or filter.



BTAS 311SV

BTAS SERIES TAKE-APART SUCTION LINE FILTER DRIERS

The BTAS is a replaceable core take-apart filter drier for suction line service ideal for commercial refrigeration applications.

FEATURES

- Full flow fittings for low pressure drop
- Corrosion resistant brass body with stainless steel bolts
- Special cartridge design exclusive to brass shell

SPECIFICATIONS

Filtration40 microns with core
 Maximum Working Pressure..... 400 psig (28 bar)
 UL/CUL File Number SA3124
 Canadian CRN0E21971.513467890YTN

MODEL NUMBER NOMENCLATURE - EXAMPLE: BTAS 311SV

SERIES	UNIT SIZE	CONNECTION SIZE	TYPE	SEQUENTIAL IDENTIFIER	CUSTOMER SPECIAL	PACK TYPE
BTAS	3	11	SV			
Brass Take-Apart Suction Line Filter Driers	Nominal Shell Diameter In Inches	In 1/8" Increments	SV = Suction Line Service	S = ODF (Omit for SAE)	Blank Thru -99	G = Customer Special (Omit for Standard)

BTAS SERIES TAKE-APART FILTER DRIERS AND CORES

UNIT SIZE (DIAMETER IN INCHES)	INLET X OUTLET CONNECTION SIZE	MODEL NUMBER	ITEM NUMBER
2	7/8" X 7/8" ODF	BTAS 27SV	049462
3	1-1/8" X 1-1/8" ODF	BTAS 39SV	049465
3	1-3/8" X 1-3/8" ODF	BTAS 311SV	049466
3	1-5/8" X 1-5/8" ODF	BTAS 313SV	049467
3	2-1/8" X 2-1/8" ODF	BTAS 317SV	049468
4	1-3/8" X 1-3/8" ODF	BTAS 411SV	064169
4	1-5/8" X 1-5/8" ODF	BTAS 413SV	049470
4	2-1/8" X 2-1/8" ODF	BTAS 417SV	049471
4	2-5/8" X 2-5/8" ODF	BTAS 421SV	049472
5	2-1/8" X 2-1/8" ODF	BTAS 517SV	049473
5	2-5/8" X 2-5/8" ODF	BTAS 521SV	049474
5	3-1/8" X 3-1/8" ODF	BTAS 525SV	049475

BTAS models are shipped without filter cartridge or Filter Drier cartridge.

TYPE A-F REPLACEABLE FILTER CARTRIDGES

FOR SHELL NO.	CORE O.D.	CORE LENGTH	FILTER AREA (SQ. IN.)	WEIGHT (LBS)	MODEL NUMBER	ITEM NUMBER
BTAS 2	1 29/32	6 3/8	66	0.33	A2 F	049479
BTAS 3	2 3/4	6 7/8	115	0.50	A3 F	049480
BTAS 4	3 3/4	7 1/2	189	0.88	A4 F	049481
BTAS 5	4 5/16	8 1/2	270	1.00	A5 F	049482

TYPE A-F-D REPLACEABLE FILTER DRIER CARTRIDGES

FOR SHELL NO.	CARTRIDGE O.D.	CARTRIDGE LENGTH	DESICCANT VOLUME (CUBIC IN.)	WEIGHT (LBS)	MODEL NUMBER	ITEM NUMBER
BTAS 2	1 29/32	6 3/8	4.2	0.50	A2 FD	049483
BTAS 3	2 3/4	6 7/8	13.3	0.88	A3 FD	049484
BTAS 4	3 3/4	7 1/2	26.0	1.20	A4 FD	049485
BTAS 5	4 5/16	8 1/2	36.5	1.20	A5 FD	049486

BTAS SERIES REPLACEMENT PARTS*

DESCRIPTION	MODEL NUMBER	ITEM NUMBER
Access Valve	X-11562-2	037409
BTAS 2 Repair Kit*	KD-30519-2	065970
BTAS 3 Repair Kit*	KD-30519-3	065971
BTAS 4 Repair Kit*	KD-30519-4	065972
BTAS 5 Repair Kit*	KD-30519-5	065973
BTAS 2 Seal Ring Kit	KD-40015-1	066430
BTAS 3 Seal Ring Kit	KD-40015-2	066431
BTAS 4 Seal Ring Kit	KD-40015-3	066432
BTAS 5 Seal Ring Kit	KD-40015-4	066433

* Repair kits contain cover bolts, cover, spring and seal ring.

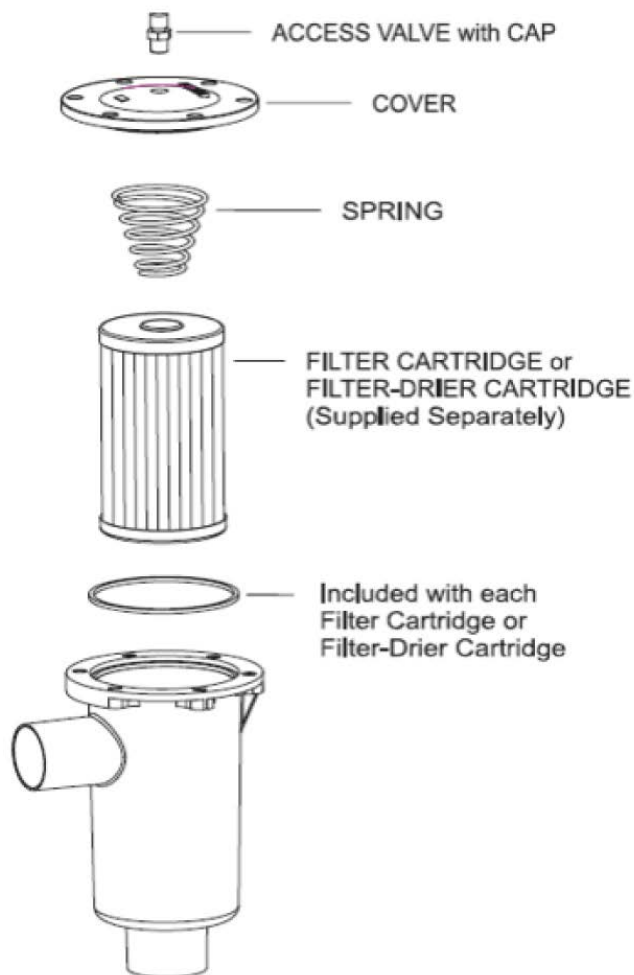

Capacity
Tables



ASD 35S5VV

ASD SERIES PREMIUM HERMETIC SUCTION LINE FILTER DRIERS

The ASD is a premium beaded suction line filter drier optimized for high moisture, acid, and solid contaminant removal.

FEATURES

- Outstanding filtration for ultimate compressor protection
- Dual access valves for easy pressure readings
- Solid copper connections
- Corrosion resistant epoxy powder paint finish

SPECIFICATIONS

Filtration 40 microns
 Maximum Working Pressure..... 500 psig (35 bar)
 UL/CUL File Number SA3124
 Canadian CRN 0E21971.513467890YTN

MODEL NUMBER NOMENCLATURE - EXAMPLE: ASD 35S5VV

SERIES	UNIT SIZE	CONNECTION STYLE	CONNECTION SIZE	ACCESS	SEQUENTIAL IDENTIFIER	CUSTOMER SPECIAL	PACK TYPE
ASD	35	S	5	VV			
Premium Hermetic Suction Line Filter Driers	In Cubic In.	S = ODF F = SAE	In 1/8" Increments	VV = Dual Access Valves	Blank Thru -99	G = Customer Special (Omit for Standard)	B1 = Bulk Pack (Omit for Individual Pack)

ASD SERIES SUCTION LINE FILTER DRIER

UNIT SIZE (CUBIC INCHES)	INLET X OUTLET CONNECTION SIZE	ACCESS	MODEL NUMBER	ITEM NUMBER
28	3/8" X 3/8" ODF	Dual	ASD 28S3VV	049168
28	3/8" X 3/8" SAE	None	ASD 28F3	056352
28	1/2" X 1/2" ODF	Dual	ASD 28S4VV	049169
35	5/8" X 5/8" SAE	Dual	ASD 35F5VV	049170
35	5/8" X 5/8" ODF	Dual	ASD 35S5VV	049171
45	3/4" X 3/4" ODF	Dual	ASD 45S6VV	049172
45	7/8" X 7/8" ODF	Dual	ASD 45S7VV	049173
50	1-1/8" X 1-1/8" ODF	Dual	ASD 50S9VV	049174
75	1-3/8" X 1-3/8" ODF	Dual	ASD 75S11VV	049175
75	1-5/8" X 1-5/8" ODF	Dual	ASD 75S13VV	049176



Capacity
Tables



SFD 13S5VV

SFD SERIES HERMETIC SUCTION LINE FILTER DRIERS

The SFD is a standard suction line beaded filter drier for use air conditioning, heat pump and refrigeration applications.

FEATURES

- Solid copper connections
- Dual access valves for easy pressure readings
- Corrosion resistant epoxy powder paint finish

SPECIFICATIONS

Filtration 40 microns
 Maximum Working Pressure..... 500 psig (35 bar)
 UL/CUL File Number SA3124
 Canadian CRN0E21971.513467890YTN

MODEL NUMBER NOMENCLATURE - Example: SFD 13S5VV

SERIES	UNIT SIZE	CONNECTION STYLE	CONNECTION SIZE	ACCESS TYPE	SEQUENTIAL IDENTIFIER	CUSTOMER SPECIAL	PACK TYPE
SFD	13	S	5	VV			
Steel Take-Apart Series	In Cubic In.	S = ODF F = SAE	In 1/8" Increments	VV = Dual Access Valves	Blank Thru -99	G = Customer Special (Omit for Standard)	B1 = Bulk Pack (Omit for Individual Pack)

SFD SERIES HERMETIC SUCTION LINE FILTER DRIERS

UNIT SIZE (CUBIC INCHES)	INLET X OUTLET CONNECTION SIZE	ACCESS TYPE	MODEL NUMBER	ITEM NUMBER
8	1/2" X 1/2" ODF	Dual	SFD 08S4VV	064045
8	5/8" X 5/8" ODF	Dual	SFD 08S5VV	064046
8	3/4" X 3/4" ODF	Dual	SFD 08S6VV	064047
13	3/8" X 3/8" ODF	Dual	SFD 13S3VV	060245
13	3/8" X 3/8" SAE	Dual	SFD 13F3VV	060244
13	1/2" X 1/2" ODF	Dual	SFD 13S4VV	060247
13	1/2" X 1/2" SAE	Dual	SFD 13F4VV	060246
13	5/8" X 5/8" ODF	Dual	SFD 13S5VV	060249
13	5/8" X 5/8" SAE	Dual	SFD 13F5VV	060248
13	3/4" X 3/4" ODF	Dual	SFD 13S6VV	060250
13	7/8" X 7/8" ODF	Dual	SFD 13S7VV	060262
27	3/4" X 3/4" ODF	Dual	SFD 27S6VV	056505
27	7/8" X 7/8" ODF	Dual	SFD 27S7VV	060251
27	1-1/8" X 1-1/8" ODF	Dual	SFD 27S9VV	060252
54	1-3/8" X 1-3/8" ODF	Dual	SFD 54S11VV	060253
54	1-5/8" X 1-5/8" ODF	Dual	SFD 54S13VV	060254



Capacity
Tables

CSFD SERIES HERMETIC COMPACT SUCTION LINE FILTER DRIERS



CSFD 14S7VV

The CSFD is a hermetic suction line filter drier used for moisture, acid and solid contaminant removal.

FEATURES

- Dual access valves for easy pressure readings
- High acid removal capacity
- Solid copper fittings for easy brazing
- Corrosion resistant epoxy powder paint finish

SPECIFICATIONS

Filtration 40 microns
 Maximum Working Pressure..... 500 psig (35 bar)
 UL/CUL File Number SA3124
 Canadian CRN 0E21971.513467890YTN

MODEL NUMBER NOMENCLATURE - Example: CSFD 14S4VV

SERIES	UNIT SIZE	CONNECTION STYLE	CONNECTION SIZE	ACCESS	SEQUENTIAL IDENTIFIER	CUSTOMER SPECIAL	PACK TYPE
CSFD	14	S	4	VV			
Hermetic Suction Line Filter Driers	In Cubic In.	S = ODF	In 1/8" Increments	VV = Dual Access Valve	Blank Thru -99	G = Customer Special (Omit for Standard)	B1 = Bulk Pack (Omit for Individual Pack)

CSFD COMPACT SERIES SUCTION LINE FILTER DRIERS

UNIT SIZE (CUBIC INCHES)	INLET X OUTLET CONNECTION SIZE	ACCESS TYPE	MODEL NUMBER	ITEM NUMBER
14	1/2" X 1/2" ODF	Dual	CSFD 14S4VV	062231
14	5/8" X 5/8" ODF	Dual	CSFD 14S5VV	062232
14	3/4" X 3/4" ODF	Dual	CSFD 14S6VV	062233
14	7/8" X 7/8" ODF	Dual	CSFD 14S7VV	062234
14	1-1/8" X 1-1/8" ODF	Dual	CSFD 14S9VV	062235



Capacity
Tables



ASK 306SVVHH

ASK SERIES HERMETIC SUCTION LINE FILTER DRIERS

The ASK is a refrigerant filter drier that utilizes a solid core with an activated carbon blend to maximize acid, moisture and wax removal.

FEATURES

- Dual access valves for easy pressure readings
- Corrosion resistant epoxy powder paint finish
- Activated carbon blend for soluble contaminant and wax
- Solid copper connections

SPECIFICATIONS

Filtration 40 microns
 Maximum Working Pressure..... 500 psig (35 bar)
 UL/CUL File Number SA3124
 Canadian CRN0E21971.513467890YTN

MODEL NUMBER NOMENCLATURE - Example: ASK 306SVVHH

SERIES	UNIT SIZE	CONNECTION SIZE	CONNECTION STYLE	ACCESS	DESICCANT TYPE	SEQUENTIAL IDENTIFIER	CUSTOMER SPECIAL	PACK TYPE
ASK	30	6	S	VV	HH			
Hermetic Suction Line Filter Driers	In Cubic In.	In 1/8" Increments	S = ODF	VV = Dual Access Valves	HH = Activated Carbon	Blank Thru -99	G = Customer Special (Omit for Standard)	B1 = Bulk Pack (Omit for Individual Pack)

ASK SERIES SUCTION LINE FILTER DRIER

UNIT SIZE (CUBIC INCHES)	INLET X OUTLET CONNECTION SIZE	ACCESS	MODEL NUMBER	ITEM NUMBER
16	5/8" X 5/8" ODF	Dual	ASK 165SVVHH	056508
16	3/4" X 3/4" ODF	Dual	ASK 166SVVHH	056509
16	7/8" X 7/8" ODF	Dual	ASK 167SVVHH	056510
30	3/4" X 3/4" ODF	Dual	ASK 306SVVHH	056511
30	7/8" X 7/8" ODF	Dual	ASK 307SVVHH	056512
30	1-1/8" X 1-1/8" ODF	Dual	ASK 309SVVHH	056513



Capacity
Tables



ASF 45S6VV

ASF SERIES HERMETIC SUCTION LINE FILTERS

The ASF is a refrigerant filter drier designed to protect the compressor from dirt and all solid contaminants.

FEATURES

- Dual access valves for easy pressure readings
- Solid copper connections
- Corrosion resistant epoxy powder paint finish

SPECIFICATIONS

Filtration 40 microns
 Maximum Working Pressure..... 500 psig (35 bar)
 UL/CUL File Number SA3124
 Canadian CRN0E21971.513467890YTN

MODEL NUMBER NOMENCLATURE - Example: ASF 35S5VV

SERIES	UNIT SIZE	CONNECTION STYLE	CONNECTION SIZE	ACCESS	SEQUENTIAL IDENTIFIER	CUSTOMER SPECIAL	PACK TYPE
ASF	35	S	5	VV			
Hermetic Suction Line Filter Driers	In Cubic In.	S = ODF F = SAE	In 1/8" Increments	VV = Dual Access Valves	Blank Thru -99	G = Customer Special (Omit for Standard)	B1 = Bulk Pack (Omit for Individual Pack)

ASF SERIES SUCTION LINE FILTERS

UNIT SIZE (CUBIC INCHES)	INLET X OUTLET CONNECTION SIZE	ACCESS TYPE	MODEL NUMBER	ITEM NUMBER
11	1/2" X 1/2" ODF	None	ASF 11S4	062961
11	5/8" X 5/8" ODF	None	ASF 11S5	062962
28	3/8" X 3/8" ODF	Dual	ASF 28S3VV	049177
28	1/2" X 1/2" ODF	Dual	ASF 28S4VV	049178
28	7/8" X 7/8" ODF	Dual	ASF 28S7VV	062963
28	1-1/8" X 1-1/8" ODF	Dual	ASF 28S9VV	062964
35	5/8" X 5/8" ODF	Dual	ASF 35S5VV	049180
35	5/8" X 5/8" SAE	Dual	ASF 35F5VV	049179
45	3/8" X 3/8" SAE	Dual	ASF 45F3VV	059999
45	3/4" X 3/4" ODF	Dual	ASF 45S6VV	049181
45	7/8" X 7/8" ODF	Dual	ASF 45S7VV	049182
50	1-1/8" X 1-1/8" ODF	Dual	ASF 50S9VV	049183
64	2-1/8" X 2-1/8" ODF	Single	ASF 64S17V	063113
64	2-5/8" X 2-5/8" ODF	Single	ASF 64S21V	063115
75	1-3/8" X 1-3/8" ODF	Dual	ASF 75S11VV	049184
75	1-5/8" X 1-5/8" ODF	Dual	ASF 75S13VV	049185



Capacity
Tables

HERMETIC SUCTION LINE FILTER DRIER FLOW CAPACITIES

MODEL NUMBER	CONNECTIONS (IN)	FLOW CAPACITY IN TONS REFRIGERANT ¹ (FOR KW, MULTIPLY TONS BY 3.5) ²											
		R-12				R-134a / R-450A / R-513A				R-744			
		EVAPORATOR TEMPERATURE (°F)											
		40	20	0	-20	40	20	0	-20	20	0	-20	-40
		PRESSURE DROP (PSI)											
		2.0	1.5	1.0	0.5	2.0	1.5	1.0	0.5	6.0	5.0	4.0	3.0
ASD 28S3VV	3/8 ODF	1.1	0.6	0.5	0.5	1.1	0.6	0.5	0.4	7.2	6.3	6.8	8.5
ASD 28S4VV	1/2 ODF	1.8	1.2	0.8	0.7	1.9	1.2	0.8	0.6	11.8	10.2	10.6	14.2
ASD 35F5VV	5/8 SAE	2.1	1.4	1.1	0.9	2.2	1.4	1.0	0.8	13.7	12.2	12.9	17.0
ASD 35S5VV	5/8 ODF	2.8	1.9	1.4	1.1	2.9	1.9	1.3	1.0	18.1	15.6	16.7	22.7
ASD 45S6VV	3/4 ODF	3.8	2.5	1.8	1.2	3.9	2.5	1.7	1.1	21.8	22.4	24.2	28.4
ASD 45S7VV	7/8 ODF	5.0	3.6	2.3	1.5	5.1	3.5	2.2	1.3	28.7	29.2	31.1	36.9
ASD 50S9VV	1-1/8 ODF	7.1	5.0	3.2	1.8	7.3	4.9	3.0	1.6	41.1	41.3	43.2	49.6
ASD 75S11VV	1-3/8 ODF	8.6	5.9	3.7	2.0	8.8	5.8	3.5	1.8	50.5	49.6	50.8	56.7
ASD 75S13VV	1-5/8 ODF	9.0	6.2	3.9	2.1	9.3	6.1	3.7	1.9	53.9	52.0	53.0	59.6
ASF 28S3VV	3/8 ODF	1.2	0.8	0.5	0.5	1.2	0.8	0.5	0.4	7.5	6.3	6.8	9.9
ASF 28S4VV	1/2 ODF	1.9	1.3	0.9	0.8	2.0	1.3	0.9	0.7	12.8	11.2	12.1	17.0
ASF 35F5VV	5/8 SAE	2.2	1.5	1.1	0.9	2.3	1.5	1.0	0.8	14.6	12.6	13.6	18.4
ASF 35S5VV	5/8 ODF	3.2	2.2	1.6	1.4	3.3	2.2	1.5	1.2	20.6	18.0	19.7	26.9
ASF 45S6VV	3/4 ODF	4.7	3.2	2.3	1.8	4.8	3.1	2.2	1.6	30.5	26.7	28.0	38.3
ASF 45S7VV	7/8 ODF	6.5	4.8	3.3	1.9	6.7	4.7	3.1	1.7	37.4	38.9	42.4	51.0
ASF 50S9VV	1-1/8 ODF	9.2	6.8	4.5	2.6	9.5	6.7	4.3	2.3	59.2	58.3	62.1	69.5
ASF 64S17VV	2-1/8 ODF	25.3	18.3	12.6	7.2	26.0	18.0	12.0	6.4	127.8	131.2	144.0	170.2
ASF 75S11VV	1-3/8 ODF	11.7	8.8	5.9	3.4	12.0	8.7	5.6	3.0	49.9	72.9	83.4	95.0
ASF 75S13VV	1-5/8 ODF	13.6	9.7	6.6	3.8	14.0	9.5	6.3	3.4	74.8	72.9	75.8	92.2
ASK 165S-VVHH	5/8 ODF	1.9	1.4	0.8	0.6	2.0	1.4	0.8	0.5	10.6	10.2	10.6	12.8
ASK 166SVVHH	3/4 ODF	2.4	1.7	1.1	0.7	2.5	1.7	1.0	0.6	13.1	12.6	12.9	14.2
ASK 167SVVHH	7/8 ODF	2.6	1.8	1.2	0.7	2.7	1.8	1.1	0.6	14.3	13.6	14.4	15.6
ASK 306SVVHH	3/4 ODF	3.3	2.3	1.5	0.9	3.4	2.3	1.4	0.8	17.1	17.0	17.4	19.9
ASK 307SVVHH	7/8 ODF	3.5	2.5	1.6	0.9	3.6	2.5	1.5	0.8	19.0	18.5	18.9	21.3
ASK 309SVVHH	1-1/8 ODF	3.8	2.6	1.7	0.9	3.9	2.6	1.6	0.8	20.3	19.4	19.7	22.7
CSFD 14S4VV	1/2 ODF	1.3	0.9	0.5	0.3	1.3	0.9	0.5	0.3	6.2	6.3	6.8	8.5
CSFD 14S5VV	5/8 ODF	2.2	1.5	0.9	0.6	2.3	1.5	0.9	0.5	11.2	11.7	12.1	14.2
CSFD 14S6VV	3/4 ODF	3.0	2.1	1.3	0.8	3.1	2.1	1.3	0.7	15.3	15.6	16.7	19.9
CSFD 14S7VV	7/8 ODF	3.2	2.2	1.5	0.8	3.3	2.2	1.4	0.7	16.2	16.5	17.4	21.3
CSFD 14S9VV	1-1/8 ODF	4.4	3.1	1.9	1.1	4.5	3.0	1.8	1.0	21.8	22.4	23.5	28.4
SFD 13F3VV	3/8 SAE	0.7	0.4	0.2	0.1	0.7	0.4	0.2	0.1	4.4	3.9	3.0	2.8
SFD 13S3VV	3/8 ODF	1.3	0.8	0.5	0.2	1.3	0.8	0.5	0.2	6.9	6.3	6.1	7.1
SFD 13F4VV	1/2 SAE	1.5	1.0	0.6	0.3	1.5	1.0	0.6	0.3	7.5	7.8	8.3	9.9
SFD 13S4VV	1/2 ODF	2.2	1.5	1.1	0.6	2.3	1.5	1.0	0.5	10.9	11.2	12.1	14.2
SFD 13F5VV	5/8 SAE	2.4	1.7	1.2	0.7	2.5	1.7	1.1	0.6	11.5	11.7	12.1	14.2
SFD 13S5VV	5/8 ODF	3.0	2.1	1.4	0.8	3.1	2.1	1.3	0.7	15.3	15.6	16.7	19.9
SFD 13S6VV	3/4 ODF	4.0	2.7	1.8	1.0	4.1	2.7	1.7	0.9	19.9	20.4	21.2	25.5
SFD 13S7VV	7/8 ODF	4.3	3.1	2.0	1.1	4.4	3.0	1.9	1.0	22.4	22.4	22.7	26.9
SFD 27S6VV	3/4 ODF	4.0	2.7	1.8	1.0	4.1	2.7	1.7	0.9	19.9	20.4	21.2	25.5
SFD 27S7VV	7/8 ODF	4.6	3.2	2.0	1.1	4.7	3.1	1.9	1.0	23.4	23.3	24.2	28.4
SFD 27S9VV	1-1/8 ODF	5.1	3.5	2.1	1.1	5.2	3.4	2.0	1.0	26.5	26.2	26.5	29.8
SFD 54S11VV	1-3/8 ODF	4.4	2.9	1.8	1.0	4.5	2.9	1.7	0.9	22.8	22.4	22.7	25.5
SFD 54S13VV	1-5/8 ODF	4.5	3.1	1.9	1.0	4.6	3.0	1.8	0.9	23.1	22.8	24.2	28.4

¹ All ratings in accordance with ARI Standard 730-04.

² Example: 1.0 tons x 3.5 = 3.5 kW

HERMETIC SUCTION LINE FILTER DRIER FLOW CAPACITIES

MODEL NUMBER	CONNECTIONS (IN)	FLOW CAPACITY IN TONS REFRIGERANT ¹ (FOR KW, MULTIPLY TONS BY 3.5) ²														
		R-22 / R-448A / R-449A					R-407C					R-410A				
		EVAPORATOR TEMPERATURE (°F)														
		40	20	0	-20	-40	40	20	0	-20	-40	40	20	0	-20	-40
		PRESSURE DROP (PSI)														
		3.0	2.0	1.5	1.0	0.5	3.0	2.0	1.5	1.0	0.5	3.0	2.0	1.5	1.0	0.5
ASD 28S3VV	3/8 ODF	2.3	1.3	0.9	0.6	0.5	2.1	1.2	0.8	0.5	0.4	2.8	1.6	1.1	0.7	0.6
ASD 28S4VV	1/2 ODF	3.8	2.1	1.4	1.0	0.8	3.5	1.9	1.2	0.9	0.7	4.6	2.6	1.7	1.2	1.0
ASD 35F5VV	5/8 SAE	4.4	2.5	1.7	1.2	0.9	4.1	2.3	1.5	1.0	0.7	5.3	3.0	2.1	1.5	1.1
ASD 35S5VV	5/8 ODF	5.8	3.2	2.2	1.6	1.0	5.4	2.9	1.9	1.4	0.8	7.0	3.9	2.7	2.0	1.3
ASD 45S6VV	3/4 ODF	7.0	4.6	3.2	2.0	1.1	6.5	4.2	2.8	1.7	0.9	8.5	5.6	3.9	2.5	1.4
ASD 45S7VV	7/8 ODF	9.2	6.0	4.1	2.6	1.4	8.5	5.5	3.6	2.3	1.2	11.2	7.3	5.0	3.2	1.8
ASD 50S9VV	1-1/8 ODF	13.2	8.5	5.7	3.5	1.8	12.2	7.7	5.0	3.1	1.5	16.0	10.3	7.0	4.3	2.3
ASD 75S11VV	1-3/8 ODF	16.2	10.2	6.7	4.0	2.0	15.0	9.3	5.9	3.5	1.7	19.6	12.4	8.2	5.0	2.5
ASD 75S13VV	1-5/8 ODF	17.3	10.7	7.0	4.2	2.1	16.0	9.7	6.2	3.7	1.7	21.0	13.0	8.6	5.2	2.6
ASF 28S3VV	3/8 ODF	2.4	1.3	0.9	0.7	0.5	2.2	1.2	0.8	0.6	0.4	2.9	1.6	1.1	0.9	0.6
ASF 28S4VV	1/2 ODF	4.1	2.3	1.6	1.2	0.9	3.8	2.1	1.4	1.0	0.7	5.0	2.8	2.0	1.5	1.1
ASF 35F5VV	5/8 SAE	4.7	2.6	1.8	1.3	1.0	4.4	2.4	1.6	1.1	0.8	5.7	3.2	2.2	1.6	1.3
ASF 35S5VV	5/8 ODF	6.6	3.7	2.6	1.9	1.6	6.1	3.4	2.3	1.7	1.3	8.0	4.5	3.2	2.4	2.0
ASF 45S6VV	3/4 ODF	9.8	5.5	3.7	2.7	2.2	9.1	5.0	3.3	2.4	1.8	11.9	6.7	4.5	3.4	2.8
ASF 45S7VV	7/8 ODF	12.0	8.0	5.6	3.6	3.0	11.1	7.3	5.0	3.1	2.5	14.6	9.7	6.9	4.5	3.8
ASF 50S9VV	1-1/8 ODF	19.0	12.0	8.2	4.9	2.6	17.6	10.9	7.3	4.3	2.2	23.0	14.6	10.1	6.1	3.3
ASF 64S17VV	2-1/8 ODF	41.0	27.0	19.0	12.0	6.9	38.0	24.5	16.8	10.5	5.7	49.7	32.8	23.3	14.9	8.6
ASF 75S11VV	1-3/8 ODF	16.0	15.0	11.0	6.7	3.3	14.8	13.6	9.7	5.8	2.7	19.4	18.2	13.5	8.3	4.1
ASF 75S13VV	1-5/8 ODF	24.0	15.0	10.0	6.5	3.2	22.2	13.6	8.9	5.7	2.7	29.1	18.2	12.3	8.1	4.0
ASK 165S-VVHH	5/8 ODF	3.4	2.1	1.4	0.9	0.4	3.2	1.9	1.2	0.8	0.3	4.1	2.6	1.7	1.1	0.5
ASK 166S-VVHH	3/4 ODF	4.2	2.6	1.7	1.0	0.5	3.9	2.4	1.5	0.9	0.4	5.1	3.2	2.1	1.2	0.6
ASK 167S-VVHH	7/8 ODF	4.6	2.8	1.9	1.1	0.6	4.3	2.5	1.7	1.0	0.5	5.6	3.4	2.3	1.4	0.8
ASK 306S-VVHH	3/4 ODF	5.5	3.5	2.3	1.4	0.8	5.1	3.2	2.0	1.2	0.7	6.7	4.3	2.8	1.7	1.0
ASK 307S-VVHH	7/8 ODF	6.1	3.8	2.5	1.5	0.8	5.7	3.5	2.2	1.3	0.7	7.4	4.6	3.1	1.9	1.0
ASK 309S-VVHH	1-1/8 ODF	6.5	4.0	2.6	1.6	0.8	6.0	3.6	2.3	1.4	0.7	7.9	4.9	3.2	2.0	1.0
CSFD 14S4VV	1/2 ODF	2.0	1.3	0.9	0.6	0.3	1.9	1.2	0.8	0.5	0.2	2.4	1.6	1.1	0.7	0.4
CSFD 14S5VV	5/8 ODF	3.6	2.4	1.6	1.0	0.5	3.3	2.2	1.4	0.9	0.4	4.4	2.9	2.0	1.2	0.6
CSFD 14S6VV	3/4 ODF	4.9	3.2	2.2	1.4	0.7	4.5	2.9	1.9	1.2	0.6	5.9	3.9	2.7	1.7	0.9
CSFD 14S7VV	7/8 ODF	5.2	3.4	2.3	1.5	0.8	4.8	3.1	2.0	1.3	0.7	6.3	4.1	2.8	1.9	1.0
CSFD 14S9VV	1-1/8 ODF	7.0	4.6	3.1	2.0	1.0	6.5	4.2	2.7	1.7	0.8	8.5	5.6	3.8	2.5	1.3
SFD 13F3VV	3/8 SAE	1.4	0.8	0.4	0.2	0.1	1.3	0.7	0.4	0.2	0.1	1.7	1.0	0.5	0.2	0.1
SFD 13S3VV	3/8 ODF	2.2	1.3	0.8	0.5	0.2	2.0	1.2	0.7	0.4	0.2	2.7	1.6	1.0	0.6	0.3
SFD 13F4VV	1/2 SAE	2.4	1.6	1.1	0.7	0.4	2.2	1.5	1.0	0.6	0.3	2.9	1.9	1.3	0.9	0.5
SFD 13S4VV	1/2 ODF	3.5	2.3	1.6	1.0	0.6	3.2	2.1	1.4	0.9	0.5	4.2	2.8	2.0	1.2	0.8
SFD 13F5VV	5/8 SAE	3.7	2.4	1.6	1.0	0.6	3.4	2.2	1.4	0.9	0.5	4.5	2.9	2.0	1.2	0.8
SFD 13S5VV	5/8 ODF	4.9	3.2	2.2	1.4	0.8	4.5	2.9	1.9	1.2	0.7	5.9	3.9	2.7	1.7	1.0
SFD 13S6VV	3/4 ODF	6.4	4.2	2.8	1.8	1.0	5.9	3.8	2.5	1.6	0.8	7.8	5.1	3.4	2.2	1.3
SFD 13S7VV	7/8 ODF	7.2	4.6	3.0	1.9	1.0	6.7	4.2	2.7	1.7	0.8	8.7	5.6	3.7	2.4	1.3
SFD 27S6VV	3/4 ODF	6.4	4.2	2.8	1.8	1.0	5.9	3.8	2.5	1.6	0.8	7.8	5.1	3.4	2.2	1.3
SFD 27S7VV	7/8 ODF	7.5	4.8	3.2	2.0	1.1	7.0	4.4	2.8	1.7	0.9	9.1	5.8	3.9	2.5	1.4
SFD 27S9VV	1-1/8 ODF	8.5	5.4	3.5	2.1	1.1	7.9	4.9	3.1	1.8	0.9	10.3	6.6	4.3	2.6	1.4
SFD 54S11VV	1-3/8 ODF	7.3	4.6	3.0	1.8	1.0	6.8	4.2	2.7	1.6	0.8	8.9	5.6	3.7	2.2	1.3
SFD 54S13VV	1-5/8 ODF	7.4	4.7	3.2	2.0	1.0	6.9	4.3	2.8	1.7	0.8	9.0	5.7	3.9	2.5	1.3

¹ All ratings in accordance with ARI Standard 730-04.

² Example: 1.0 tons x 3.5 = 3.5 kW

HERMETIC SUCTION LINE FILTER DRIER FLOW CAPACITIES

MODEL NUMBER	CONNECTIONS (IN)	FLOW CAPACITY IN TONS REFRIGERANT ¹ (FOR KW, MULTIPLY TONS BY 3.5) ²								
		R-502				R-404A / R-507				
		EVAPORATOR TEMPERATURE (°F)								
		40	20	0	-20	40	20	0	-20	-40
		PRESSURE DROP (PSI)								
		3.0	2.0	1.5	1.0	3.0	2.0	1.5	1.0	0.5
ASD 28S3VV	3/8 ODF	2.2	1.1	0.7	0.5	2.1	1.1	0.7	0.5	0.3
ASD 28S4VV	1/2 ODF	3.7	1.8	1.1	0.7	3.6	1.8	1.1	0.7	0.5
ASD 35F5VV	5/8 SAE	4.2	2.1	1.3	0.9	4.1	2.1	1.3	0.9	0.6
ASD 35S5VV	5/8 ODF	5.6	2.8	1.7	1.1	5.4	2.8	1.7	1.1	0.8
ASD 45S6VV	3/4 ODF	6.6	3.7	2.5	1.5	6.4	3.7	2.5	1.6	1.0
ASD 45S7VV	7/8 ODF	7.7	4.8	3.3	1.9	7.5	4.8	3.3	2.0	1.1
ASD 50S9VV	1-1/8 ODF	11.0	6.9	4.6	2.7	11.0	6.9	4.6	2.8	1.4
ASD 75S11VV	1-3/8 ODF	14.0	8.4	5.4	3.1	14.0	8.4	5.4	3.2	1.6
ASD 75S13VV	1-5/8 ODF	15.0	8.9	5.7	3.3	15.0	8.9	5.7	3.4	1.7
ASF 28S3VV	3/8 ODF	2.3	1.1	0.7	0.5	2.2	1.1	0.7	0.5	0.3
ASF 28S4VV	1/2 ODF	3.9	2.0	1.2	0.8	3.8	2.0	1.2	0.8	0.6
ASF 35F5VV	5/8 SAE	4.5	2.3	1.4	0.9	4.4	2.3	1.4	0.9	0.7
ASF 35S5VV	5/8 ODF	6.3	3.2	2.0	1.4	6.1	3.2	2.0	1.4	1.0
ASF 45S6VV	3/4 ODF	9.4	4.7	2.9	1.8	9.1	4.7	2.9	1.9	1.4
ASF 45S7VV	7/8 ODF	10.0	6.3	4.5	2.7	9.8	6.3	4.5	2.8	1.5
ASF 50S9VV	1-1/8 ODF	16.0	10.0	6.6	3.9	16.0	10.0	6.7	4.0	2.0
ASF 64S17VV	2-1/8 ODF	36.0	23.0	15.0	9.5	35.0	23.0	15.0	9.8	5.2
ASF 75S11VV	1-3/8 ODF	21.0	13.0	8.2	4.9	20.0	13.0	8.3	5.1	2.6
ASF 75S13VV	1-5/8 ODF	22.0	13.0	8.3	5.0	21.0	13.0	8.4	5.2	2.7
ASK 165S-VVHH	5/8 ODF	3.3	1.9	1.2	0.8	3.2	1.9	1.2	0.8	0.3
ASK 166S-VVHH	3/4 ODF	4.0	2.4	1.6	0.9	3.9	2.4	1.6	0.9	0.5
ASK 167S-VVHH	7/8 ODF	4.4	2.6	1.7	1.0	4.3	2.6	1.7	1.0	0.6
ASK 306S-VVHH	3/4 ODF	5.2	3.2	2.2	1.2	5.0	3.2	2.2	1.2	0.7
ASK 307S-VVHH	7/8 ODF	5.8	3.5	2.3	1.4	5.6	3.5	2.3	1.4	0.7
ASK 309S-VVHH	1-1/8 ODF	6.2	3.7	2.4	1.4	6.0	3.7	2.4	1.5	0.7
CSFD 14S4VV	1/2 ODF	1.3	0.8	0.5	0.3	1.3	0.8	0.5	0.3	0.2
CSFD 14S5VV	5/8 ODF	2.7	1.7	1.1	0.7	2.6	1.7	1.1	0.7	0.3
CSFD 14S6VV	3/4 ODF	3.7	2.3	1.5	0.9	3.6	2.3	1.5	0.9	0.5
CSFD 14S7VV	7/8 ODF	4.0	2.4	1.6	1.0	3.9	2.4	1.6	1.0	0.5
CSFD 14S9VV	1-1/8 ODF	5.1	3.1	2.0	1.3	4.9	3.1	2.0	1.3	0.7
SFD 13F3VV	3/8 SAE	1.3	0.7	0.4	0.2	1.3	0.7	0.4	0.2	0.1
SFD 13S3VV	3/8 ODF	2.0	1.1	0.7	0.4	1.9	1.1	0.7	0.4	0.2
SFD 13F4VV	1/2 SAE	2.2	1.3	0.9	0.5	2.1	1.3	0.9	0.5	0.3
SFD 13S4VV	1/2 ODF	3.1	1.9	1.3	0.8	3.0	1.9	1.3	0.8	0.4
SFD 13F5VV	5/8 SAE	3.3	2.0	1.4	0.9	3.2	2.0	1.4	0.9	0.5
SFD 13S5VV	5/8 ODF	4.3	2.7	1.8	1.1	4.2	2.7	1.8	1.1	0.6
SFD 13S6VV	3/4 ODF	5.8	3.5	2.3	1.4	5.6	3.5	2.3	1.4	0.7
SFD 13S7VV	7/8 ODF	6.5	3.9	2.6	1.4	6.3	3.9	2.6	1.5	0.8
SFD 27S6VV	3/4 ODF	5.8	3.5	2.3	1.4	5.6	3.5	2.3	1.4	0.7
SFD 27S7VV	7/8 ODF	6.7	4.1	2.7	1.5	6.5	4.1	2.7	1.6	0.8
SFD 27S9VV	1-1/8 ODF	7.7	4.6	3.0	1.6	7.5	4.6	3.0	1.7	0.9
SFD 54S11VV	1-3/8 ODF	6.6	3.9	2.5	1.4	6.4	3.9	2.5	1.5	0.7
SFD 54S13VV	1-5/8 ODF	6.7	4.0	2.6	1.5	6.5	4.0	2.6	1.6	0.8

¹ All ratings in accordance with ARI Standard 730-04.

² Example: 1.0 tons x 3.5 = 3.5 kW

TAKE-APART SUCTION LINE FILTER DRIER FLOW CAPACITIES

MODEL NUMBER	CONNECTIONS (IN)	FILTER DRIER CARTRIDGE	FLOW CAPACITY IN TONS REFRGERANT ¹ (FOR KW, MULTIPLY TONS BY 3.5) ₂							
			R-12				R-134a / R-450A / R-513A			
			EVAPORATOR TEMPERATURE (°F)							
			40	20	0	-20	40	20	0	-20
			PRESSURE DROP (PSI)							
2	1.5	1	0.5	2	1.5	1	0.5			
ADKS 30013T	1-5/8 ODF	(3) F 100 Filter	24.0	17.0	12.0	7.0	25.0	17.0	11.0	6.2
ADKS 30017T	2-1/8 ODF	(3) F 100 Filter	42.0	31.0	20.0	12.0	43.0	30.0	19.0	11.0
ADKS 40017T	2-1/8 ODF	(4) F100 Filter	44.0	32.0	21.0	12.0	45.0	31.0	20.0	11.0
ADKS 40021T	2-5/8 ODF	(4) F100 Filter	66.0	48.0	32.0	19.0	68.0	47.0	30.0	17.0
ADKS 30013T	1-5/8 ODF	(3) 100 cu in Core	19.0	14.0	9.1	5.5	20.0	14.0	8.7	4.9
ADKS 30017T	2-1/8 ODF	(3) 100 cu in Core	30.0	22.0	15.0	8.7	31.0	22.0	14.0	7.7
ADKS 40017T	2-1/8 ODF	(4) 100 cu in Core	33.0	23.0	16.0	9.5	34.0	23.0	15.0	8.4
ADKS 40021T	2-5/8 ODF	(4) 100 cu in Core	48.0	35.0	23.0	14.0	49.0	34.0	22.0	12.0
BTAS 27SV	7/8 ODF	A2 F Filter	4.7	3.4	2.2	1.2	4.8	3.3	2.1	1.1
BTAS 39SV	1-1/8 ODF	A3 F Filter	7.1	5.1	3.4	1.9	7.3	5.0	3.2	1.7
BTAS 311SV	1-3/8 ODF	A3 F Filter	7.9	5.6	3.7	2.1	8.1	5.5	3.5	1.9
BTAS 313SV	1-5/8 ODF	A3 F Filter	13.0	8.9	5.9	3.4	13.0	8.8	5.6	3.0
BTAS 317SV	2-1/8 ODF	A3 F Filter	15.0	11.0	7.2	4.2	16.0	11.0	6.9	3.7
BTAS 411SV	1-3/8 ODF	A4 F Filter	17.0	12.0	8.0	4.5	17.0	12.0	7.4	4.0
BTAS 413SV	1-5/8 ODF	A4 F Filter	20.0	15.0	10.0	5.5	21.0	14.0	9.1	4.9
BTAS 417SV	2-1/8 ODF	A4 F Filter	28.0	20.0	13.0	7.5	29.0	20.0	12.0	6.7
BTAS 421SV	2-5/8 ODF	A4 F Filter	34.0	24.0	16.0	9.1	35.0	24.0	15.0	8.1
BTAS 517SV	2-1/8 ODF	A5 F Filter	33.0	24.0	16.0	9.1	34.0	24.0	15.0	8.1
BTAS 521SV	2-5/8 ODF	A5 F Filter	44.0	32.0	21.0	12.0	45.0	31.0	20.0	11.0
BTAS 525SV	3-1/8 ODF	A5 F Filter	54.0	39.0	25.0	15.0	56.0	38.0	24.0	13.0
BTAS 25SV	5/8 ODF	A2 FD Filter Drier	2.4	1.7	1.2	0.7	2.5	1.7	1.1	0.6
BTAS 27SV	7/8 ODF	A2 FD Filter Drier	4.0	2.8	1.9	1.1	4.1	2.8	1.8	1.0
BTAS 39SV	1-1/8 ODF	A3 FD Filter Drier	5.2	3.7	2.4	1.4	5.3	3.6	2.3	1.2
BTAS 311SV	1-3/8 ODF	A3 FD Filter Drier	7.2	5.2	3.4	1.9	7.4	5.1	3.2	1.7
BTAS 313SV	1-5/8 ODF	A3 FD Filter Drier	10.0	7.4	4.8	2.8	11.0	7.3	4.6	2.5
BTAS 317SV	2-1/8 ODF	A3 FD Filter Drier	12.0	8.5	5.7	3.3	12.0	8.4	5.4	2.9
BTAS 411SV	1-3/8 ODF	A4 FD Filter Drier	15.0	11.0	7.0	4.1	15.0	11.0	6.7	3.6
BTAS 413SV	1-5/8 ODF	A4 FD Filter Drier	17.0	12.0	7.2	4.2	16.0	12.0	6.9	3.7
BTAS 417SV	2-1/8 ODF	A4 FD Filter Drier	22.0	16.0	11.0	6.1	23.0	16.0	10.0	5.4
BTAS 421SV	2-5/8 ODF	A4 FD Filter Drier	23.0	17.0	12.0	6.3	24.0	17.0	11.0	5.6
BTAS 517SV	2-1/8 ODF	A5 FD Filter Drier	27.0	19.0	13.0	7.2	28.0	19.0	12.0	6.4
BTAS 521SV	2-5/8 ODF	A5 FD Filter Drier	32.0	23.0	15.0	8.8	33.0	23.0	14.0	7.8
BTAS 525SV	3-1/8 ODF	A5 FD Filter Drier	38.0	27.0	18.0	10.0	39.0	27.0	17.0	9.2
STAS 489SV	1-1/8 ODF	(1) F 48 Filter	13.0	8.0	5.0	2.0	13.0	8.0	5.0	2.0
STAS 4811SV	1-3/8 ODF	(1) F 48 Filter	15.0	10.0	6.0	3.0	15.0	10.0	6.0	3.0
STAS 4813SV	1-5/8 ODF	(1) F 48 Filter	19.0	12.0	7.0	5.0	20.0	12.0	7.0	4.0
STAS 4817SV	2-1/8 ODF	(1) F 48 Filter	24.0	15.0	11.0	6.0	25.0	15.0	10.0	5.0
STAS 4821SV	2-5/8 ODF	(1) F 48 Filter	29.0	20.0	14.0	7.0	30.0	20.0	13.0	6.0
STAS 9617SV	2-1/8 ODF	(2) F 48 Filter	27.0	18.0	11.0	6.0	28.0	18.0	10.0	5.0
STAS 9621SV	2-5/8 ODF	(2) F 48 Filter	37.0	25.0	16.0	8.0	38.0	25.0	15.0	7.0
STAS 9625SV	3-1/8 ODF	(2) F 48 Filter	44.0	30.0	19.0	10.0	45.0	30.0	18.0	8.0
STAS 489SV	1-1/8 ODF	(1) 48 cu in Core	8.0	6.0	4.0	1.0	8.0	6.0	4.0	1.0
STAS 4811SV	1-3/8 ODF	(1) 48 cu in Core	10.0	7.0	4.0	2.0	10.0	7.0	4.0	2.0
STAS 4813SV	1-5/8 ODF	(1) 48 cu in Core	13.0	8.0	5.0	3.0	13.0	8.0	5.0	3.0
STAS 4817SV	2-1/8 ODF	(1) 48 cu in Core	17.0	10.0	7.0	5.0	17.0	10.0	7.0	4.0
STAS 4821SV	2-5/8 ODF	(1) 48 cu in Core	19.0	13.0	8.0	6.0	20.0	13.0	8.0	5.0
STAS 9617SV	2-1/8 ODF	(2) 48 cu in Core	18.0	12.0	6.0	5.0	18.0	12.0	6.0	4.0
STAS 9621SV	2-5/8 ODF	(2) 48 cu in Core	24.0	17.0	11.0	6.0	25.0	17.0	10.0	5.0
STAS 9625SV	3-1/8 ODF	(2) 48 cu in Core	27.0	19.0	14.0	7.4	29.0	23.0	16.0	7.0

¹ All ratings in accordance with ARI Standard 730-04.

² Example: 1.0 tons x 3.5 = 3.5 kW

TAKE-APART SUCTION LINE FILTER DRIER FLOW CAPACITIES

MODEL NUMBER	CONNECTIONS (IN)	FILTER DRIER CARTRIDGE	FLOW CAPACITY IN TONS REFRGERANT ¹ (For kW, Multiply Tons By 3.5) ²														
			R-22 / R-448A / R-449A					R-407C					R-410A				
			EVAPORATOR TEMPERATURE (°F)														
			40	20	0	-20	-40	40	20	0	-20	-40	40	20	0	-20	-40
			PRESSURE DROP (PSI)														
3	2	1.5	1	0.5	3	2	1.5	1	0.5	3	2	1.5	1	0.5			
ADKS 30013T	1-5/8 ODF	(3) F-100 Filter	45.0	30.0	20.0	13.0	7.0	41.7	27.3	17.7	11.3	5.8	—	—	—	—	—
ADKS 30017T	2-1/8 ODF	(3) F-100 Filter	77.0	50.0	35.0	22.0	12.0	71.4	45.5	31.0	19.2	10.0	—	—	—	—	—
ADKS 40017T	2-1/8 ODF	(4) F-100 Filter	80.0	53.0	37.0	23.0	13.0	74.2	48.2	32.8	20.0	10.8	—	—	—	—	—
ADKS 40021T	2-5/8 ODF	(4) F-100 Filter	122.0	80.0	55.0	34.0	19.0	113.1	72.7	48.7	29.6	15.8	—	—	—	—	—
ADKS 30013T	1-5/8 ODF	(3) 100 cu in Core	35.0	23.0	16.0	10.0	5.5	32.4	20.9	14.2	8.7	4.6	—	—	—	—	—
ADKS 30017T	2-1/8 ODF	(3) 100 cu in Core	56.0	37.0	25.0	16.0	8.8	51.9	33.6	22.1	13.9	7.3	—	—	—	—	—
ADKS 40017T	2-1/8 ODF	(4) 100 cu in Core	61.0	40.0	27.0	17.0	9.5	56.5	36.4	23.9	14.8	7.9	—	—	—	—	—
ADKS 40021T	2-5/8 ODF	(4) 100 cu in Core	88.0	58.0	40.0	25.0	14.0	81.6	52.7	35.4	21.8	11.6	—	—	—	—	—
BTAS 27SV	7/8 ODF	A2F Filter	8.8	5.7	3.9	2.5	1.3	8.2	5.2	3.5	2.2	1.1	—	—	—	—	—
BTAS 39SV	1-1/8 ODF	A3F Filter	14.0	8.8	5.9	3.7	2.0	13.0	8.0	5.2	3.2	1.7	—	—	—	—	—
BTAS 311SV	1-3/8 ODF	A3F Filter	15.0	10.0	6.6	4.1	2.2	13.9	9.1	5.8	3.6	1.8	—	—	—	—	—
BTAS 313SV	1-5/8 ODF	A3F Filter	24.0	16.0	11.0	6.6	3.5	22.2	14.5	9.7	5.8	2.9	—	—	—	—	—
BTAS 317SV	2-1/8 ODF	A3F Filter	29.0	19.0	13.0	8.1	4.3	26.9	17.3	11.5	7.1	3.6	—	—	—	—	—
BTAS 411SV	1-3/8 ODF	A4F Filter	31.0	20.0	14.0	8.7	4.6	28.7	18.2	12.4	7.6	3.8	—	—	—	—	—
BTAS 413SV	1-5/8 ODF	A4F Filter	38.0	25.0	17.0	11.0	5.7	35.2	22.7	15.1	9.6	4.7	—	—	—	—	—
BTAS 417SV	2-1/8 ODF	A4F Filter	53.0	34.0	23.0	15.0	7.8	49.1	30.9	20.4	13.1	6.5	—	—	—	—	—
BTAS 421SV	2-5/8 ODF	A4F Filter	64.0	42.0	29.0	18.0	10.0	59.3	38.2	25.7	15.7	8.3	—	—	—	—	—
BTAS 517SV	2-1/8 ODF	A5F Filter	63.0	41.0	28.0	18.0	9.4	58.4	37.3	24.8	15.7	7.8	—	—	—	—	—
BTAS 521SV	2-5/8 ODF	A5F Filter	84.0	54.0	37.0	23.0	12.0	77.9	49.1	32.8	20.0	10.0	—	—	—	—	—
BTAS 525SV	3-1/8 ODF	A5F Filter	103.0	67.0	46.0	29.0	15.0	95.5	60.9	40.7	25.3	12.5	—	—	—	—	—
BTAS 25SV	5/8 ODF	A2F-D Filter Drier	4.6	3.0	2.0	1.3	0.7	4.3	2.7	1.8	1.1	0.6	—	—	—	—	—
BTAS 27SV	7/8 ODF	A2F-D Filter Drier	7.5	4.9	3.3	2.1	1.1	7.0	4.5	2.9	1.8	0.9	—	—	—	—	—
BTAS 39SV	1-1/8 ODF	A3F-D Filter Drier	10.0	6.3	4.3	2.7	1.4	9.3	5.7	3.8	2.4	1.2	—	—	—	—	—
BTAS 311SV	1-3/8 ODF	A3F-D Filter Drier	14.0	8.9	6.0	3.8	2.0	13.0	8.1	5.3	3.3	1.7	—	—	—	—	—
BTAS 313SV	1-5/8 ODF	A3F-D Filter Drier	20.0	13.0	8.6	5.4	2.9	18.5	11.8	7.6	4.7	2.4	—	—	—	—	—
BTAS 317SV	2-1/8 ODF	A3F-D Filter Drier	23.0	15.0	10.0	6.3	3.4	21.3	13.6	8.9	5.5	2.8	—	—	—	—	—
BTAS 411SV	1-3/8 ODF	A4F-D Filter Drier	28.0	18.0	13.0	7.8	4.2	26.0	16.4	11.5	6.8	3.5	—	—	—	—	—
BTAS 413SV	1-5/8 ODF	A4F-D Filter Drier	29.0	19.0	14.0	8.1	4.3	26.9	17.3	11.5	7.1	3.6	—	—	—	—	—
BTAS 417SV	2-1/8 ODF	A4F-D Filter Drier	43.0	28.0	19.0	12.0	6.3	39.0	25.5	16.8	10.5	5.2	—	—	—	—	—
BTAS 421SV	2-5/8 ODF	A4F-D Filter Drier	44.0	29.0	20.0	13.0	6.5	41.0	26.4	18.0	11.0	5.4	—	—	—	—	—
BTAS 517SV	2-1/8 ODF	A5F-D Filter Drier	51.0	33.0	22.0	14.0	7.5	47.3	30.0	19.5	12.2	6.2	—	—	—	—	—
BTAS 521SV	2-5/8 ODF	A5F-D Filter Drier	61.0	40.0	27.0	17.0	9.0	56.5	36.4	23.9	14.8	7.5	—	—	—	—	—
BTAS 525SV	3-1/8 ODF	A5F-D Filter Drier	72.0	47.0	32.0	20.0	11.0	66.7	42.7	28.3	17.4	9.2	—	—	—	—	—
STAS 489SV	1-1/8 ODF	(1) F-48 Filter	22.0	14.0	10.0	6.0	2.0	20.0	13.0	9.0	5.0	2.0	27.0	17.0	12.0	7.4	2.5
STAS 4811SV	1-3/8 ODF	(1) F-48 Filter	28.0	17.0	12.0	7.0	3.0	26.0	15.0	11.0	6.0	2.0	34.0	21.0	15.0	8.6	3.7
STAS 4813SV	1-5/8 ODF	(1) F-48 Filter	35.0	20.0	15.0	8.0	4.0	32.0	18.0	13.0	7.0	3.0	43.0	24.0	18.0	9.8	4.9
STAS 4817SV	2-1/8 ODF	(1) F-48 Filter	47.0	30.0	20.0	10.0	5.0	44.0	27.0	18.0	9.0	4.0	57.0	36.0	24.0	12.0	6.2
STAS 4821SV	2-5/8 ODF	(1) F-48 Filter	60.0	40.0	25.0	15.0	7.0	56.0	36.0	22.0	13.0	6.0	73.0	48.0	30.0	18.0	8.6
STAS 9617SV	2-1/8 ODF	(2) F-48 Filter	50.0	30.0	20.0	12.0	6.0	46.0	27.0	18.0	10.0	5.0	61.0	36.0	24.0	15.0	7.4
STAS 9621SV	2-5/8 ODF	(2) F-48 Filter	70.0	43.0	28.0	17.0	8.0	65.0	39.0	25.0	15.0	7.0	85.0	52.0	34.0	21.0	9.9
STAS 9625SV	3-1/8 ODF	(2) F-48 Filter	83.0	51.0	33.0	20.0	10.0	77.0	46.0	30.0	18.0	8.5	101.0	62.0	41.0	25.0	12.0
STAS 489SV	1-1/8 ODF	(1) 48 cu in Core	15.0	9.0	7.0	4.0	1.0	14.0	8.0	6.0	3.0	1.0	18.0	11.0	8.5	4.9	1.2
STAS 4811SV	1-3/8 ODF	(1) 48 cu in Core	18.0	11.0	8.0	5.0	2.0	17.0	10.0	7.0	4.0	2.0	22.0	13.0	9.7	6.1	2.5
STAS 4813SV	1-5/8 ODF	(1) 48 cu in Core	23.0	13.0	10.0	6.0	3.0	21.0	12.0	9.0	5.0	2.0	28.0	16.0	12.0	7.4	3.7
STAS 4817SV	2-1/8 ODF	(1) 48 cu in Core	31.0	20.0	13.0	7.0	4.0	29.0	18.0	12.0	6.0	3.0	38.0	24.0	16.0	9.0	4.5
STAS 4821SV	2-5/8 ODF	(1) 48 cu in Core	40.0	27.0	17.0	10.0	5.0	37.0	25.0	15.0	9.0	4.0	49.0	33.0	21.0	12.0	6.2
STAS 9617SV	2-1/8 ODF	(2) 48 cu in Core	33.0	20.0	13.0	8.0	4.0	31.0	18.0	12.0	7.0	3.0	40.0	24.0	16.0	9.8	4.9
STAS 9621SV	2-5/8 ODF	(2) 48 cu in Core	47.0	28.0	18.0	11.0	6.0	44.0	25.0	16.0	10.0	5.0	57.0	34.0	22.0	14.0	7.4
STAS 9625SV	3-1/8 ODF	(2) 48 cu in Core	51.0	30.0	24.0	17.0	7.6	47.0	27.0	20.0	15.0	6.0	62.0	37.0	28.0	20.0	11.0

¹ All ratings in accordance with ARI Standard 730-04.

² Example: 1.0 tons x 3.5 = 3.5 kW

TAKE-APART SUCTION LINE FILTER DRIER FLOW CAPACITIES

MODEL NUMBER	CONNECTIONS (IN)	FILTER DRIER CARTRIDGE	FLOW CAPACITY IN TONS REFRGERANT ¹ (FOR KW, MULTIPLY TONS BY 3.5) ²									
			R-502					R-404A / R-507				
			EVAPORATOR TEMPERATURE (°F)									
			40	20	0	-20	-40	40	20	0	-20	-40
			PRESSURE DROP (PSI)									
3	2	1.5	1	0.5	3	2	1.5	1	0.5			
ADKS 30013T	1-5/8 ODF	(3) F-100 Filter	38.0	24.0	16.0	9.9	5.2	37.0	24.0	16.0	10.0	5.5
ADKS 30017T	2-1/8 ODF	(3) F-100 Filter	64.0	40.0	27.0	17.0	8.9	62.0	40.0	27.0	18.0	9.4
ADKS 40017T	2-1/8 ODF	(4) F-100 Filter	68.0	43.0	28.0	17.0	9.2	66.0	43.0	29.0	18.0	9.8
ADKS 40021T	2-5/8 ODF	(4) F-100 Filter	102.0	64.0	43.0	27.0	14.0	99.0	64.0	43.0	28.0	15.0
ADKS 30013T	1-5/8 ODF	(3) 100 cu in Core	30.0	19.0	12.0	7.7	4.1	29.0	19.0	13.0	8.0	4.3
ADKS 30017T	2-1/8 ODF	(3) 100 cu in Core	47.0	30.0	20.0	12.0	6.4	46.0	30.0	20.0	13.0	6.8
ADKS 40017T	2-1/8 ODF	(4) 100 cu in Core	51.0	32.0	22.0	13.0	7.0	49.0	32.0	22.0	14.0	7.4
ADKS 40021T	2-5/8 ODF	(4) 100 cu in Core	74.0	47.0	31.0	19.0	10.0	72.0	47.0	32.0	20.0	11.0
BTAS 27SV	7/8 ODF	A2F Filter	7.4	4.6	3.1	1.8	0.9	7.2	4.6	3.1	1.9	1.0
BTAS 39SV	1-1/8 ODF	A3F Filter	11.0	7.0	4.7	2.8	1.4	11.0	7.0	4.7	2.9	1.5
BTAS 311SV	1-3/8 ODF	A3F Filter	12.0	7.8	5.2	3.1	1.6	12.0	7.8	5.2	3.2	1.7
BTAS 313SV	1-5/8 ODF	A3F Filter	20.0	12.0	8.2	5.0	2.5	19.0	12.0	8.3	5.2	2.7
BTAS 317SV	2-1/8 ODF	A3F Filter	25.0	15.0	10.0	6.1	3.1	24.0	15.0	10.0	6.3	3.3
BTAS 411SV	1-3/8 ODF	A4F Filter	27.0	16.0	11.0	6.6	3.4	26.0	16.0	11.0	6.8	3.6
BTAS 413SV	1-5/8 ODF	A4F Filter	32.0	20.0	13.0	8.1	4.1	31.0	20.0	14.0	8.4	4.4
BTAS 417SV	2-1/8 ODF	A4F Filter	44.0	28.0	18.0	11.0	5.7	43.0	28.0	19.0	12.0	6.0
BTAS 421SV	2-5/8 ODF	A4F Filter	54.0	34.0	23.0	14.0	6.9	52.0	34.0	23.0	14.0	7.3
BTAS 517SV	2-1/8 ODF	A5F Filter	54.0	33.0	22.0	13.0	6.8	52.0	33.0	22.0	14.0	7.2
BTAS 521SV	2-5/8 ODF	A5F Filter	70.0	44.0	29.0	18.0	9.0	68.0	44.0	29.0	18.0	9.6
BTAS 525SV	3-1/8 ODF	A5F Filter	87.0	54.0	36.0	22.0	11.0	84.0	54.0	36.0	23.0	12.0
BTAS 25SV	5/8 ODF	A2F-D Filter Drier	3.9	2.4	1.6	1.0	0.5	3.8	2.4	1.6	1.0	0.5
BTAS 27SV	7/8 ODF	A2F-D Filter Drier	6.3	3.9	2.6	1.5	0.8	6.1	3.9	2.6	1.6	0.9
BTAS 39SV	1-1/8 ODF	A3F-D Filter Drier	8.1	5.1	3.4	2.0	1.0	7.9	5.1	3.4	2.1	1.1
BTAS 311SV	1-3/8 ODF	A3F-D Filter Drier	11.0	7.1	4.8	2.9	1.5	11.0	7.1	4.8	3.0	1.6
BTAS 313SV	1-5/8 ODF	A3F-D Filter Drier	16.0	10.0	6.7	4.1	2.1	16.0	10.0	6.8	4.2	2.2
BTAS 317SV	2-1/8 ODF	A3F-D Filter Drier	19.0	12.0	7.9	4.8	2.4	19.0	12.0	8.0	5.0	2.6
BTAS 411SV	1-3/8 ODF	A4F-D Filter Drier	24.0	15.0	10.0	5.9	3.0	23.0	15.0	10.0	6.1	3.2
BTAS 413SV	1-5/8 ODF	A4F-D Filter Drier	25.0	15.0	10.0	6.1	3.1	24.0	15.0	10.0	6.3	3.3
BTAS 417SV	2-1/8 ODF	A4F-D Filter Drier	36.0	22.0	15.0	9.0	4.6	35.0	22.0	15.0	9.3	4.9
BTAS 421SV	2-5/8 ODF	A4F-D Filter Drier	37.0	23.0	16.0	10.0	5.0	36.0	23.0	16.0	10.0	5.3
BTAS 517SV	2-1/8 ODF	A5F-D Filter Drier	42.0	27.0	18.0	11.0	4.7	41.0	27.0	18.0	11.0	5.0
BTAS 521SV	2-5/8 ODF	A5F-D Filter Drier	52.0	32.0	22.0	13.0	6.6	50.0	32.0	22.0	13.0	7.0
BTAS 525SV	3-1/8 ODF	A5F-D Filter Drier	61.0	38.0	25.0	15.0	7.8	59.0	38.0	25.0	16.0	8.3
STAS 489SV	1-1/8 ODF	(1) F-48 Filter	21.0	12.0	8.0	5.0	3.0	20.0	12.0	8.0	5.0	3.0
STAS 4811SV	1-3/8 ODF	(1) F-48 Filter	25.0	15.0	10.0	6.0	4.0	24.0	15.0	10.0	6.0	4.0
STAS 4813SV	1-5/8 ODF	(1) F-48 Filter	31.0	18.0	11.0	7.0	5.0	30.0	18.0	11.0	7.0	5.0
STAS 4817SV	2-1/8 ODF	(1) F-48 Filter	41.0	25.0	15.0	9.0	7.0	40.0	25.0	15.0	9.0	7.0
STAS 4821SV	2-5/8 ODF	(1) F-48 Filter	57.0	30.0	20.0	12.0	8.0	55.0	30.0	20.0	12.0	8.0
STAS 9617SV	2-1/8 ODF	(2) F-48 Filter	41.0	25.0	15.0	10.0	7.0	40.0	25.0	15.0	10.0	7.0
STAS 9621SV	2-5/8 ODF	(2) F-48 Filter	62.0	35.0	25.0	14.0	9.0	60.0	35.0	25.0	15.0	10.0
STAS 9625SV	3-1/8 ODF	(2) F-48 Filter	74.0	42.0	30.0	17.0	11.0	72.0	42.0	30.0	18.0	12.0
STAS 489SV	1-1/8 ODF	(1) 48 cu in Core	13.0	8.0	6.0	4.0	2.0	13.0	8.0	6.0	4.0	2.0
STAS 4811SV	1-3/8 ODF	(1) 48 cu in Core	18.0	10.0	6.5	4.5	3.0	17.0	10.0	6.5	4.5	3.0
STAS 4813SV	1-5/8 ODF	(1) 48 cu in Core	21.0	12.0	7.0	5.0	4.0	20.0	12.0	7.0	5.0	4.0
STAS 4817SV	2-1/8 ODF	(1) 48 cu in Core	28.0	17.0	10.0	6.0	5.0	27.0	17.0	10.0	6.0	5.0
STAS 4821SV	2-5/8 ODF	(1) 48 cu in Core	38.0	20.0	13.0	8.0	6.0	37.0	20.0	13.0	8.0	6.0
STAS 9617SV	2-1/8 ODF	(2) 48 cu in Core	28.0	17.0	11.0	7.0	5.0	27.0	17.0	11.0	7.0	5.0
STAS 9621SV	2-5/8 ODF	(2) 48 cu in Core	41.0	23.0	17.0	10.0	7.0	40.0	23.0	17.0	10.0	7.0
STAS 9625SV	3-1/8 ODF	(2) 48 cu in Core	49.0	27.0	20.0	12.0	8.0	47.0	27.0	20.0	12.0	8.0

¹ All ratings in accordance with ARI Standard 730-04.

² Example: 1.0 tons x 3.5 = 3.5 kW